

DIAGNOSTIC DESIGN

Preliminary Design Review

Materials

- 316 stainless steel
- PPPL will silver plate all screws
- Parts will be darkened
- Screws to be secured by spot-welding silver wire

Total Assembled View 1

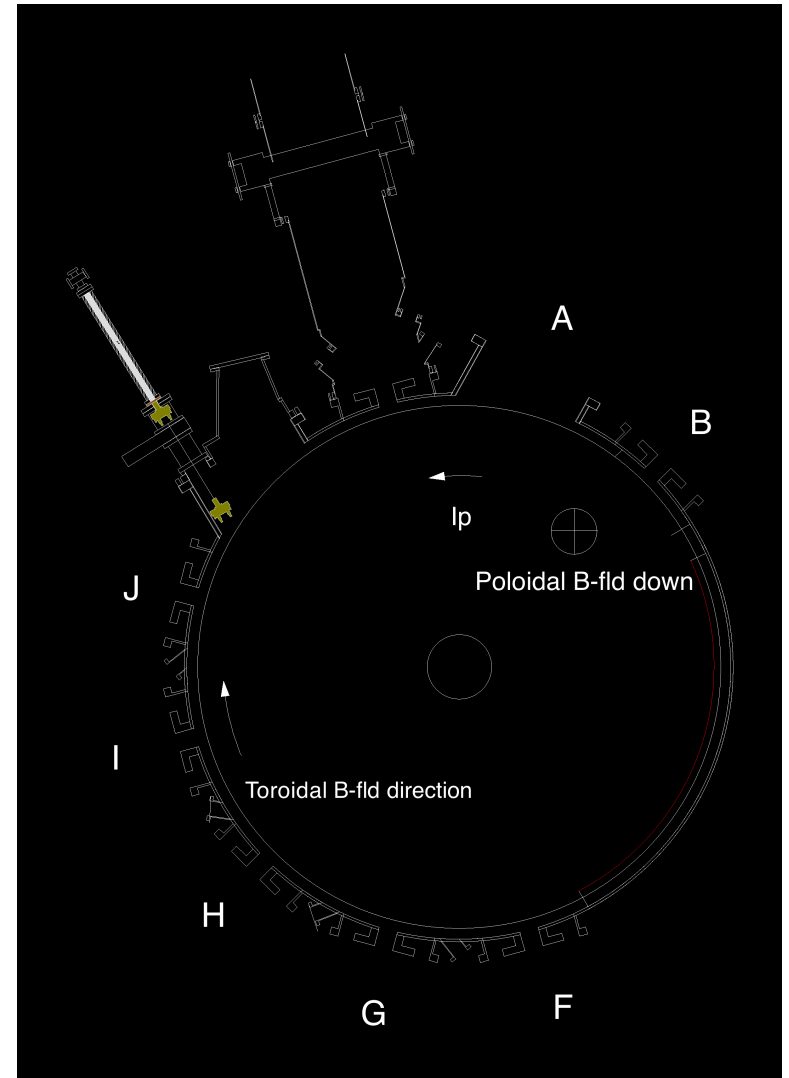
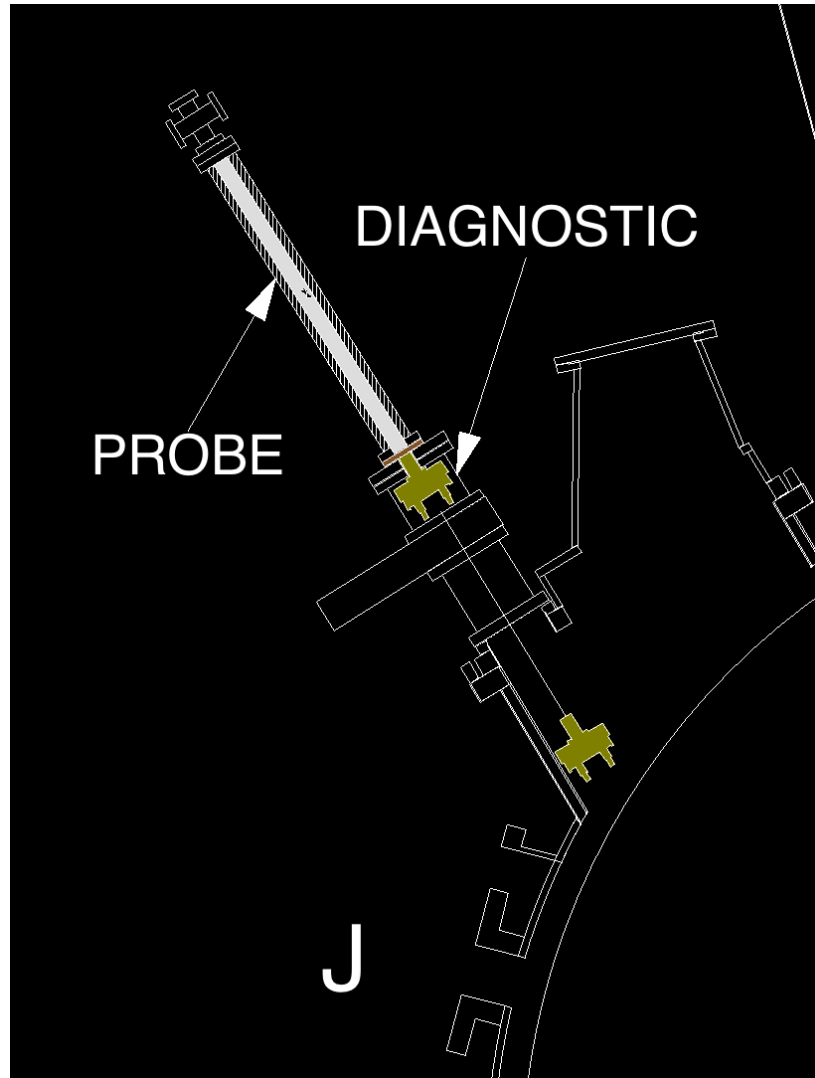

Total Assembled View 2

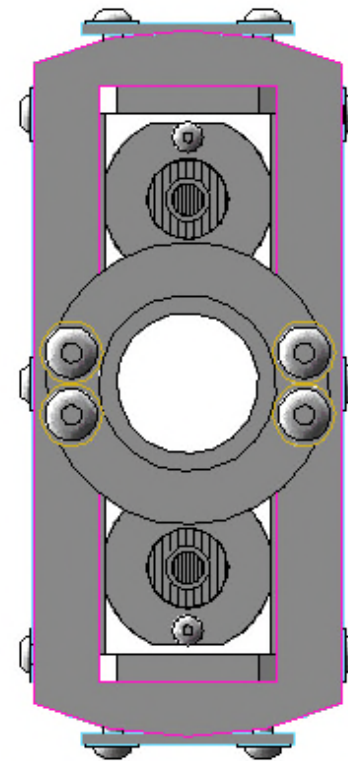
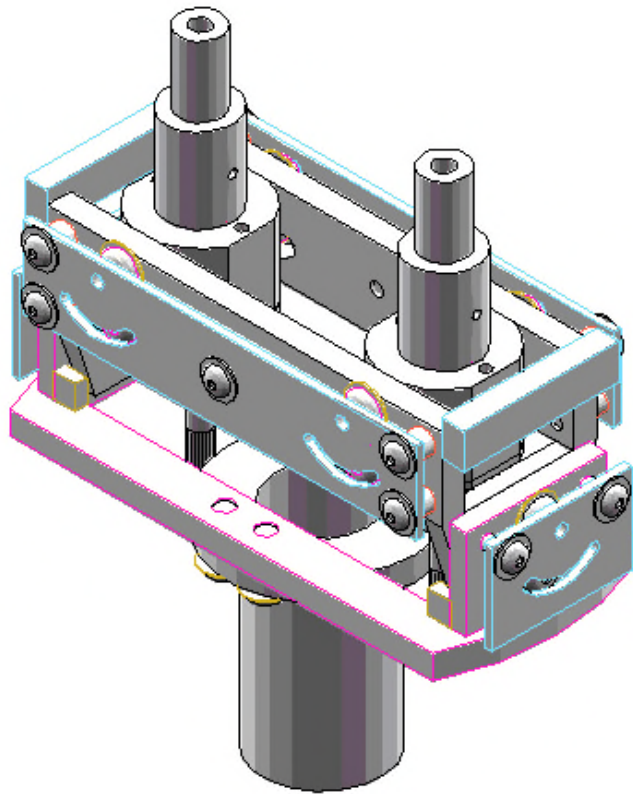

Total Assembled View 2

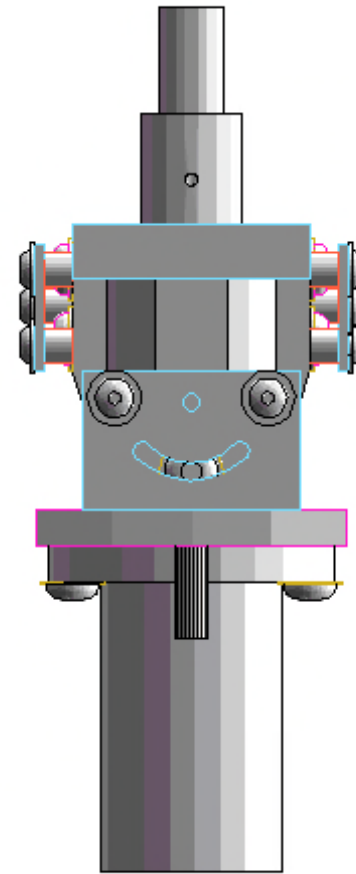
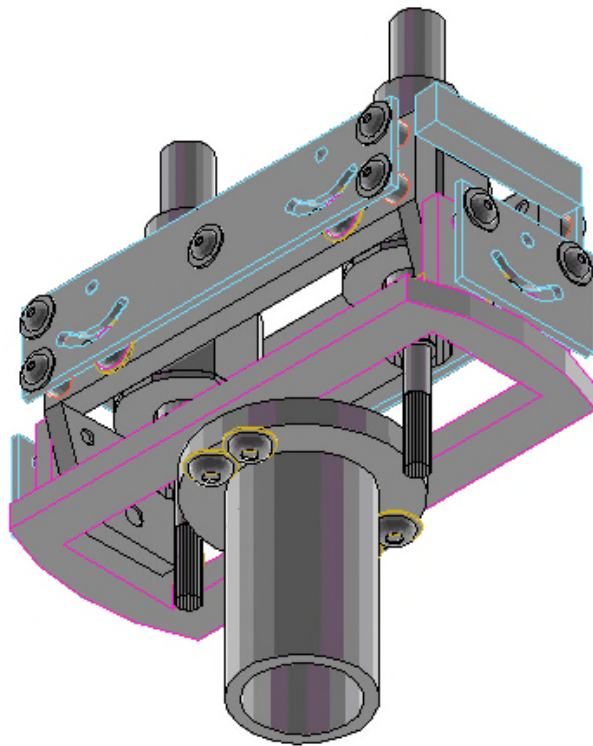

Total Assembled View 2

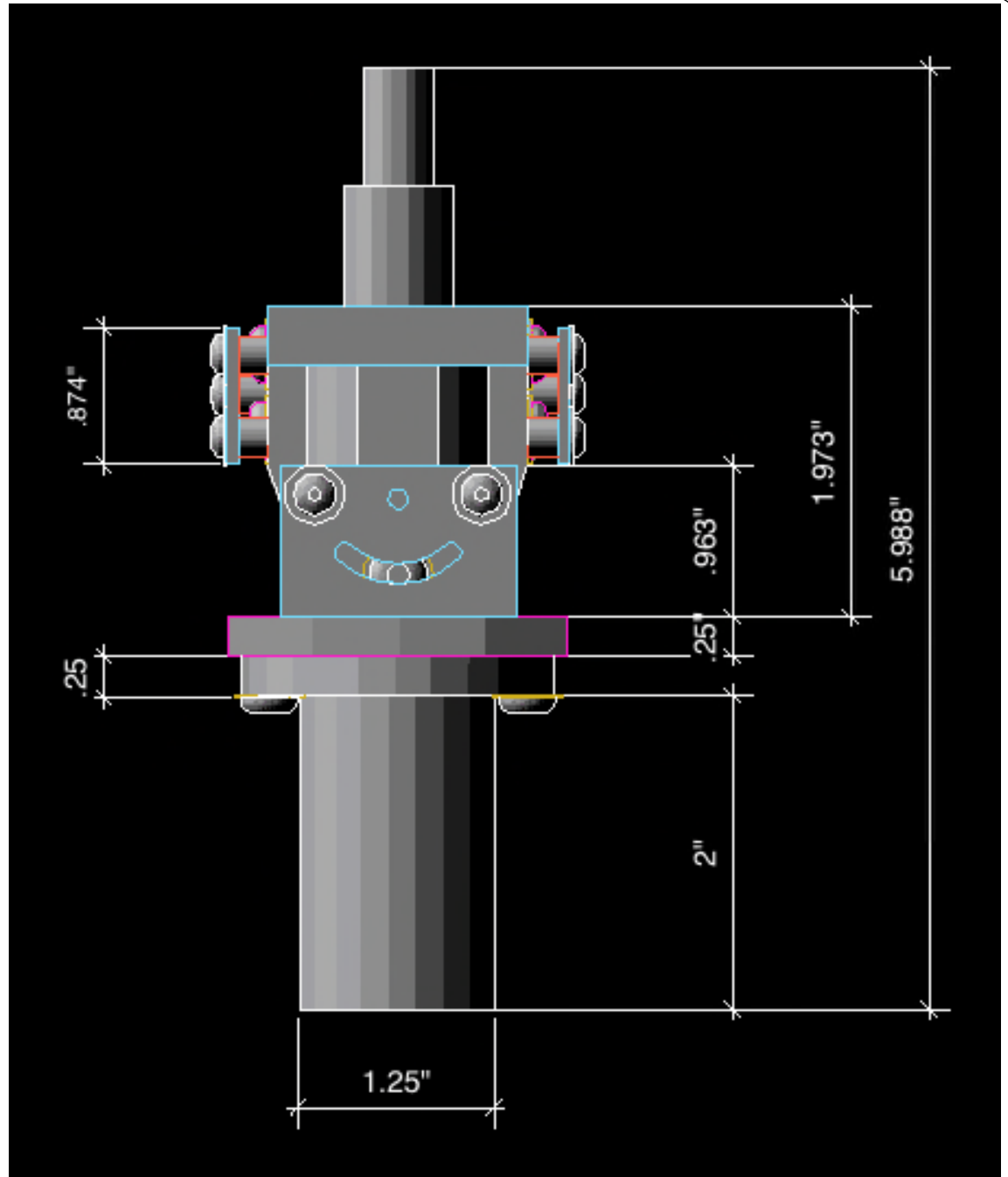

Total Assembled View 2

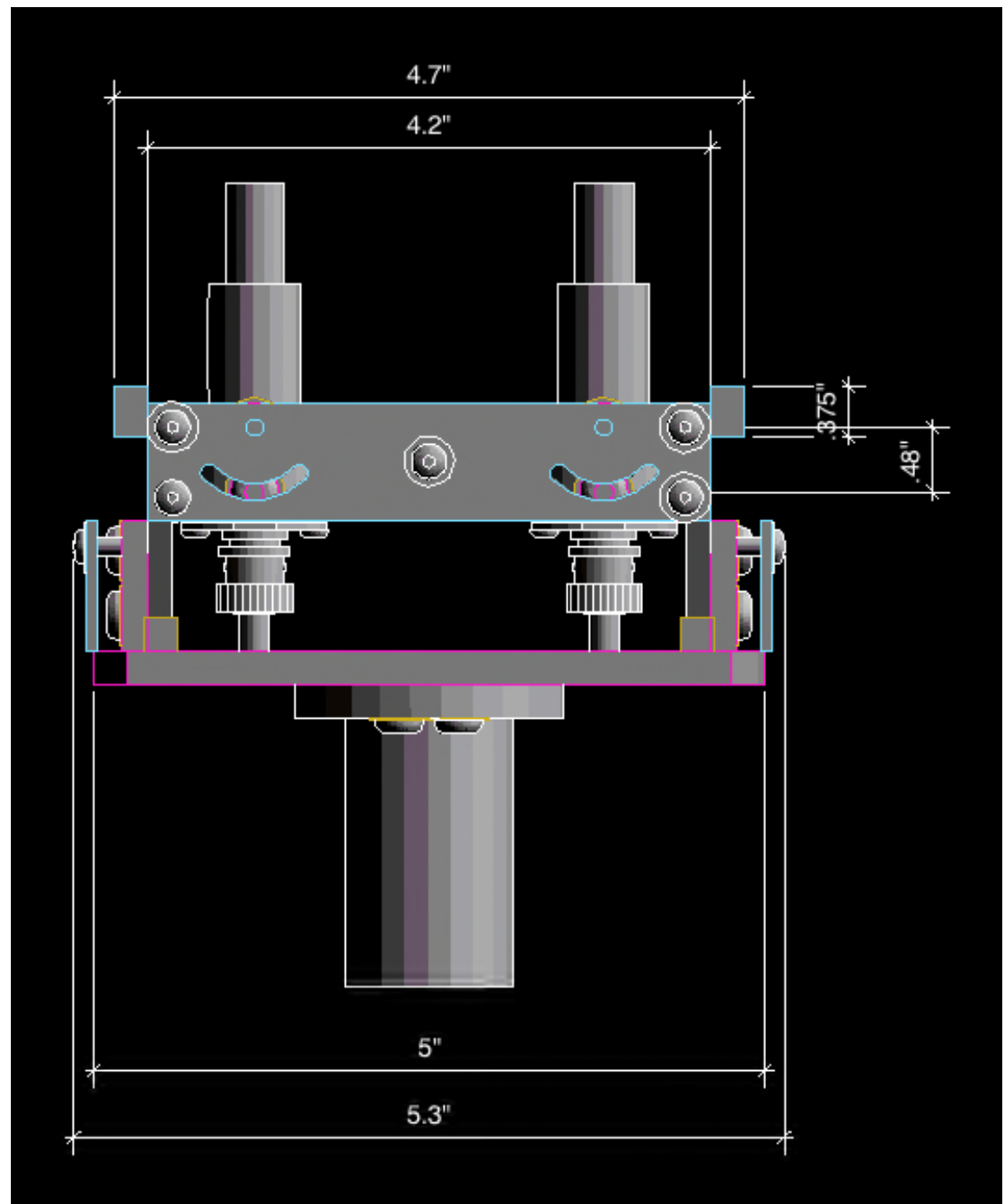

Mounts 1, 2, 3

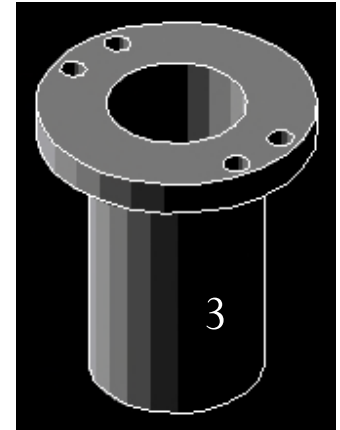
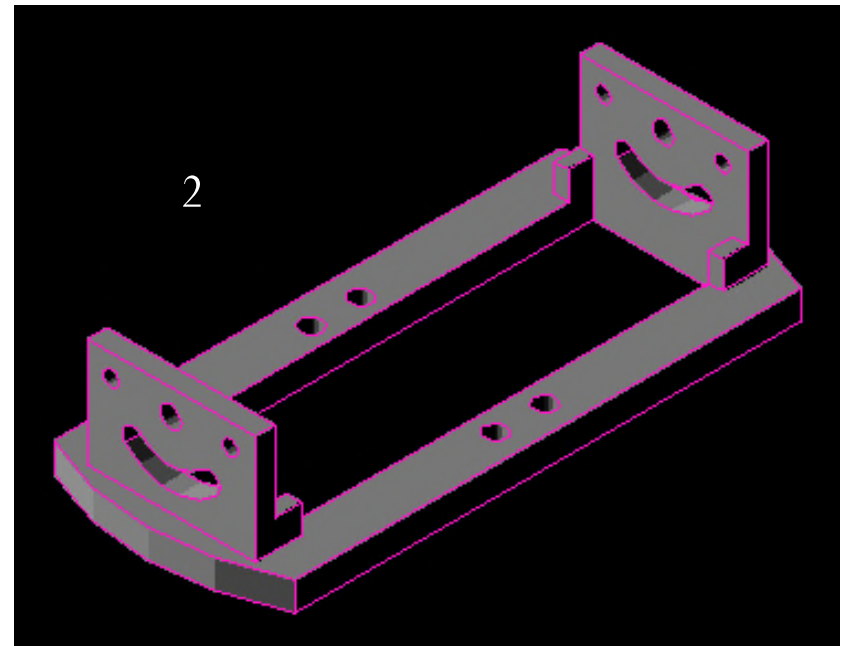
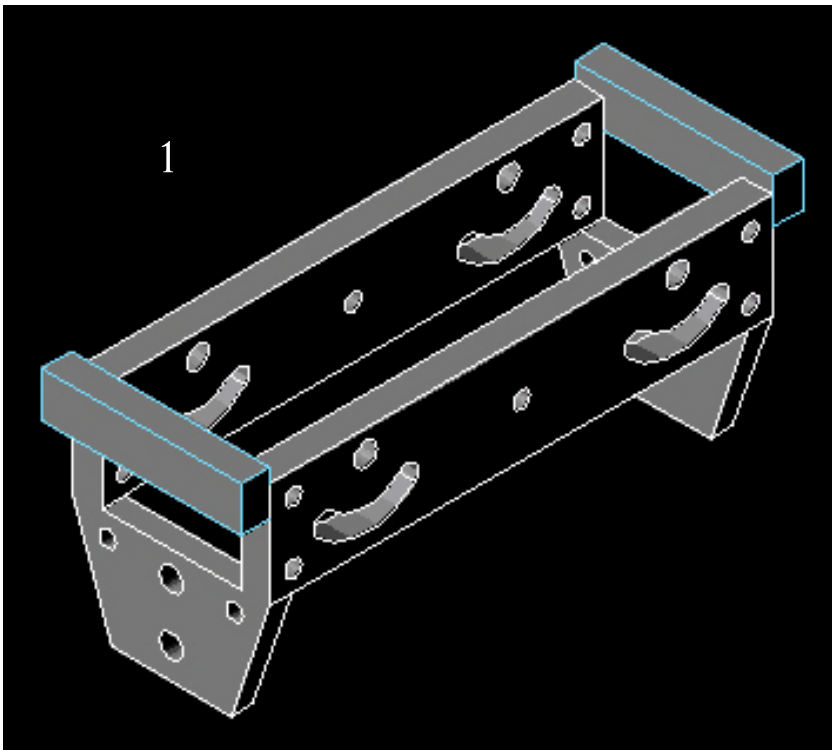

Module Assembled View 1

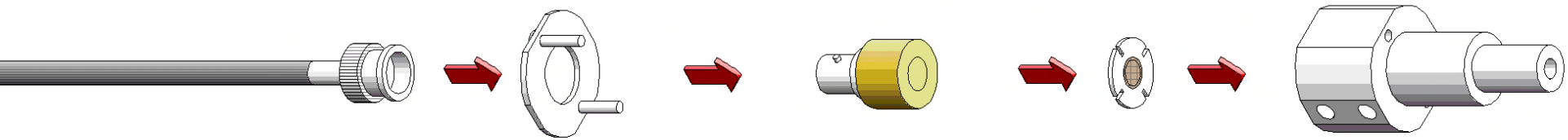

Cable

Base

Detector

Washer

Module

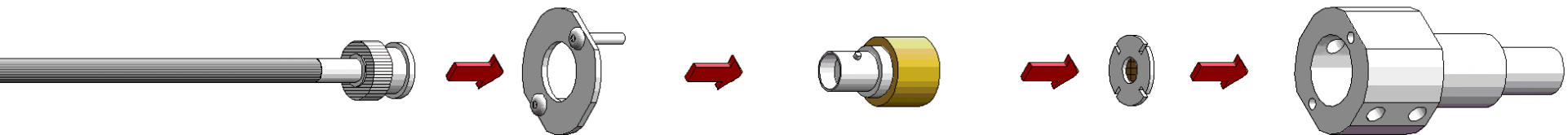

Module Assembled View 2

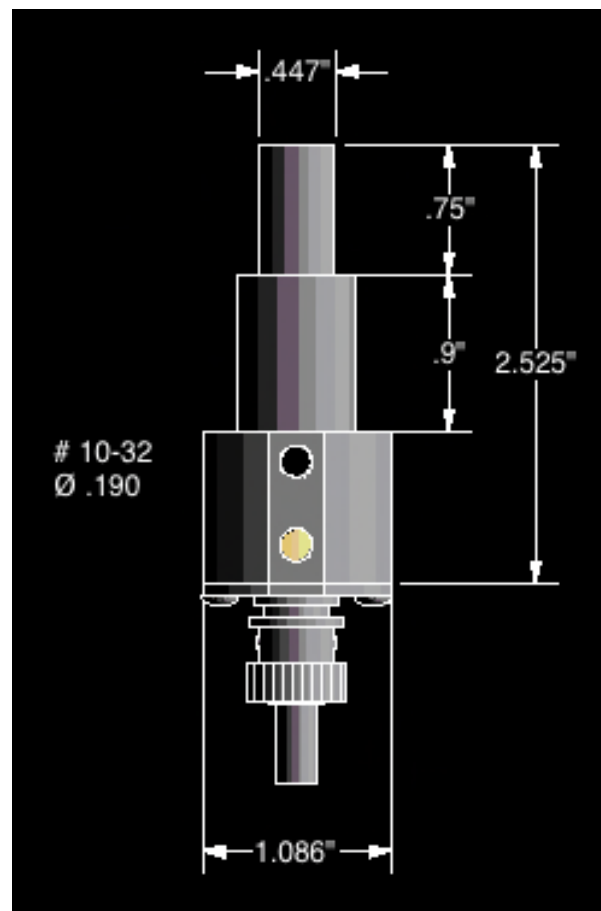

Module Rotation

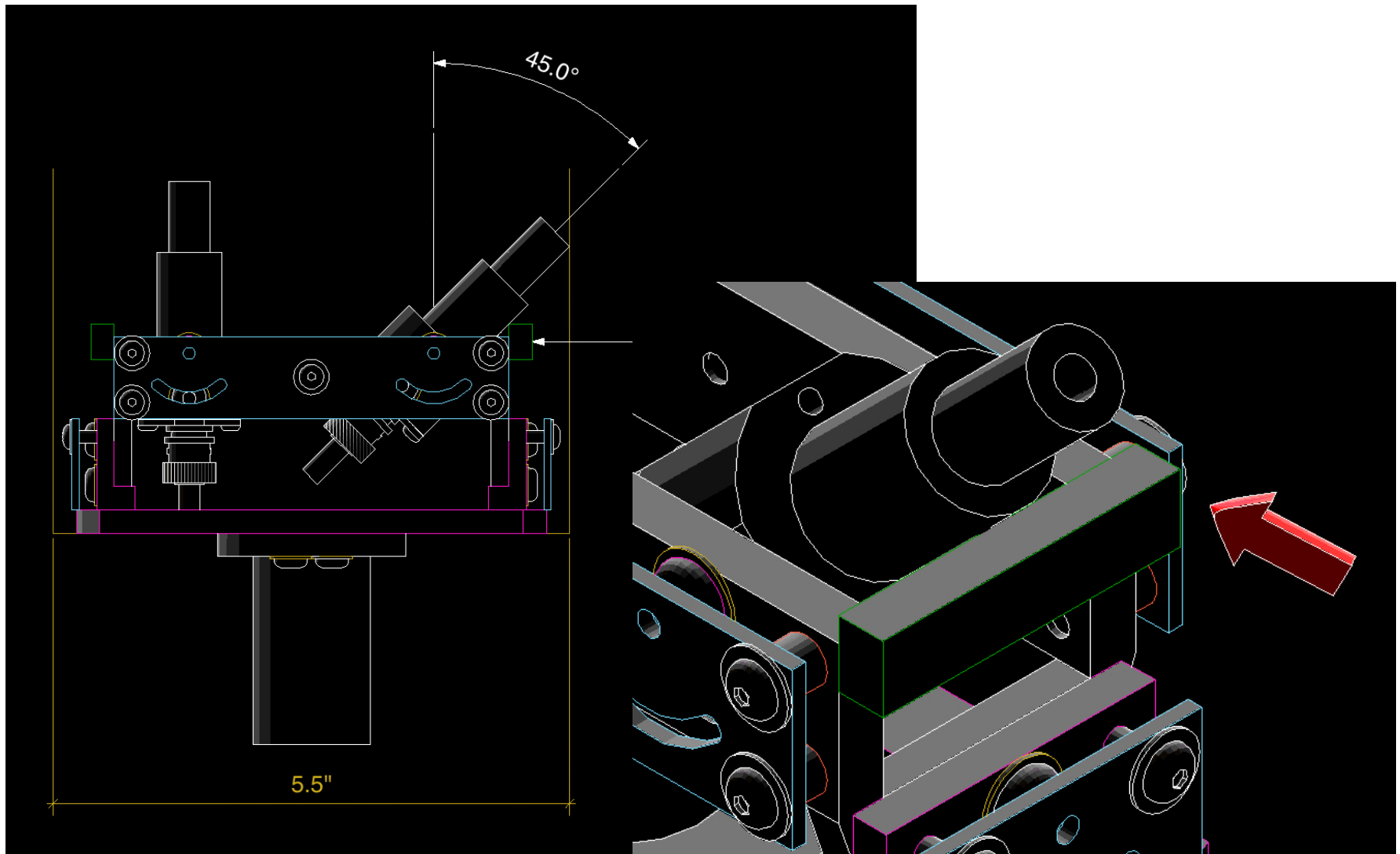

Mount 1 Rotation

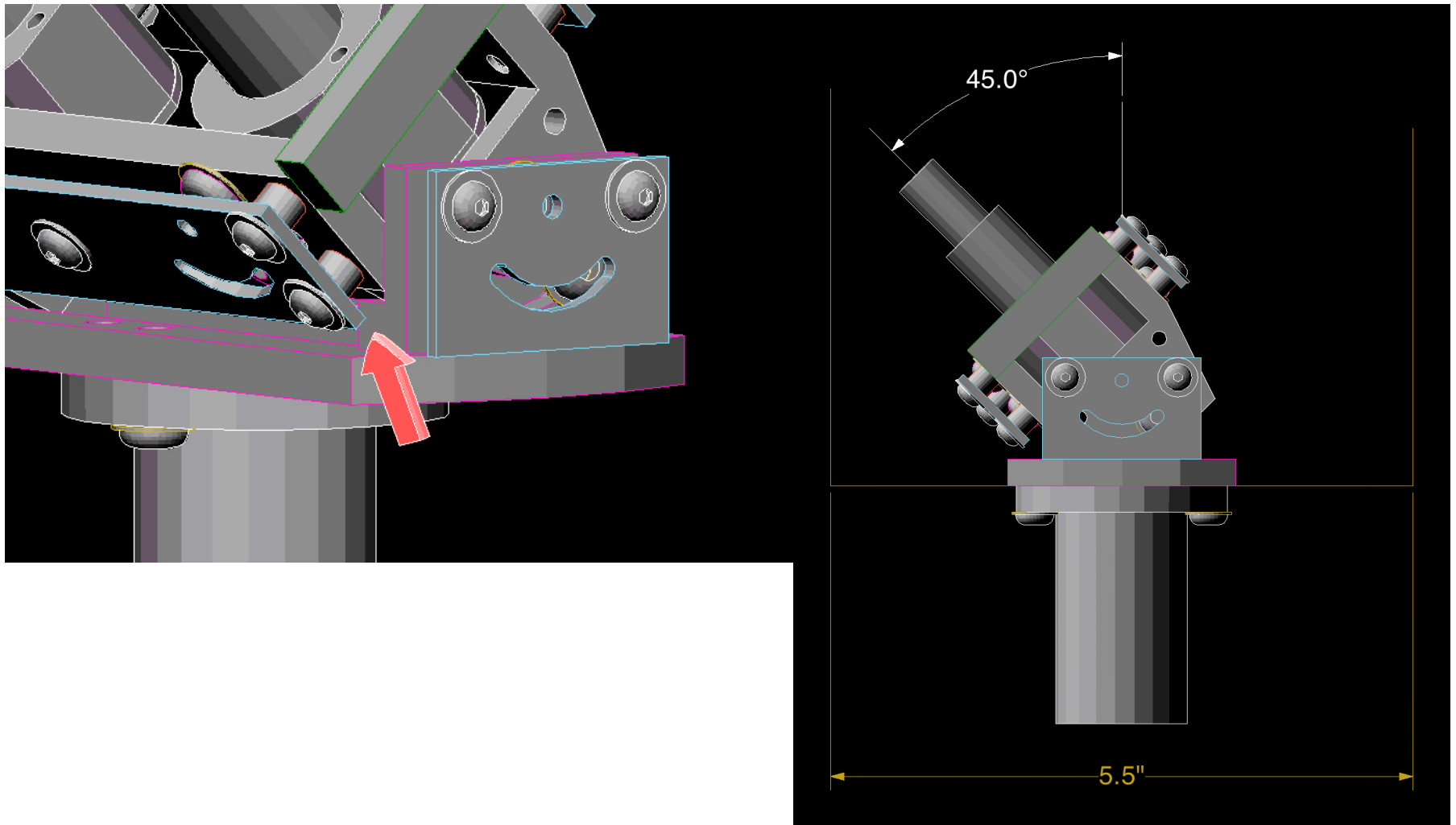

Covers

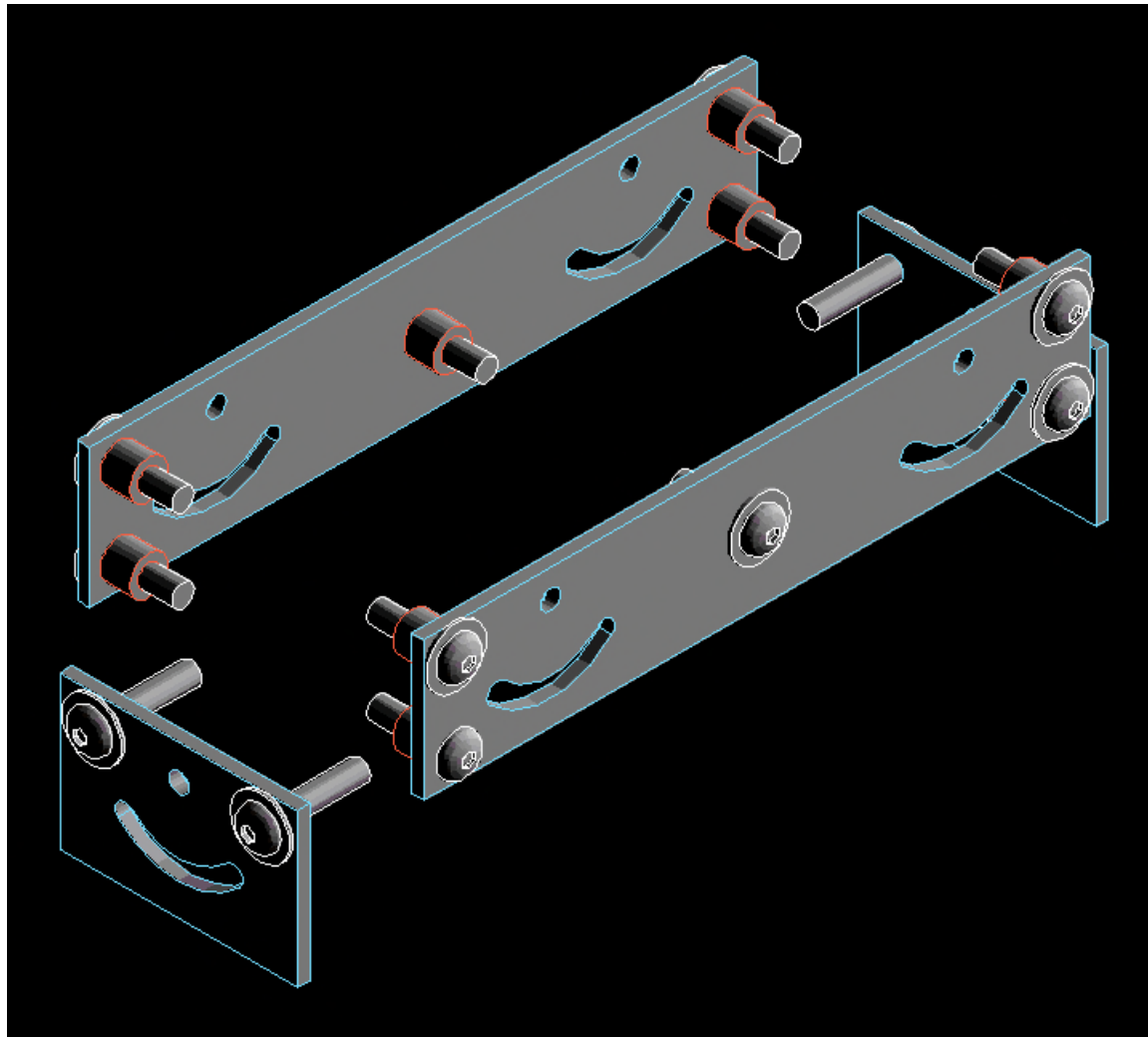

Covers

- Practical for changing module and mount rotation angle
- Holes are large enough for Allen Key to fit, but not for the socket cap screw to fall out
- Screws securing cover are spot-welded

