

PROTON DETECTOR (PD)

Electrical Design Review

June 19th, 2013

Ramona Perez



Electrical Design Review

- Installation of PD equipment
 - RP Access Cube
 - RP Linkbox
 - MD05 Cubicle
- Electrical Design
 - Diagrams & Earthing Points
 - Power Requirements
 - Installation Requirements
 - Safety Requirements
- Timeline

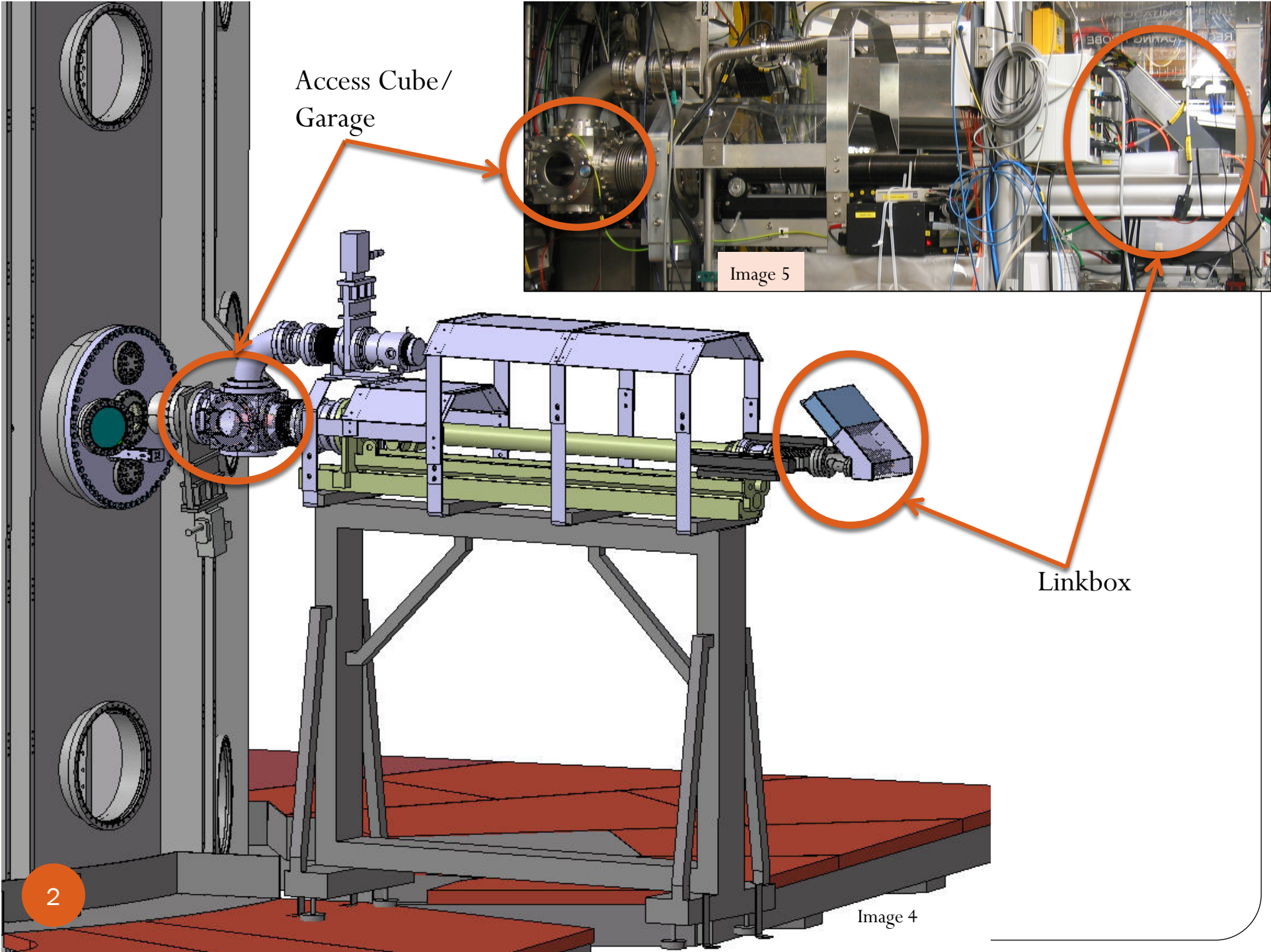

MAST RP Access Cube

- MAST will connect non terminated cable ends from detectors to RP connector

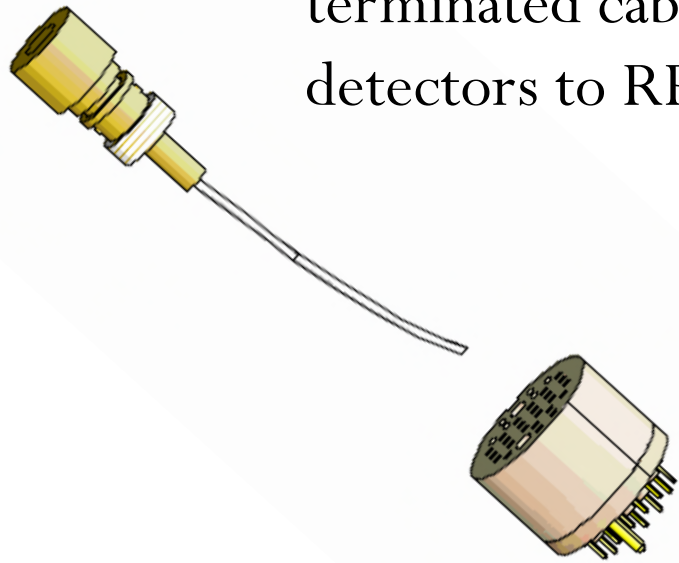

Image 8

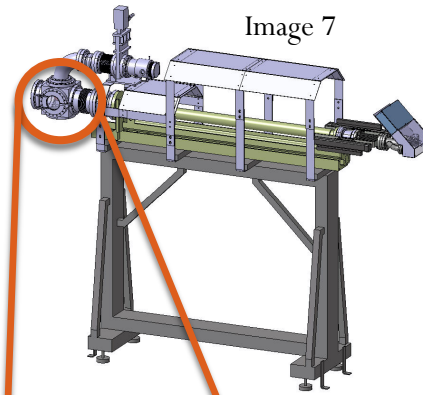

Image 7

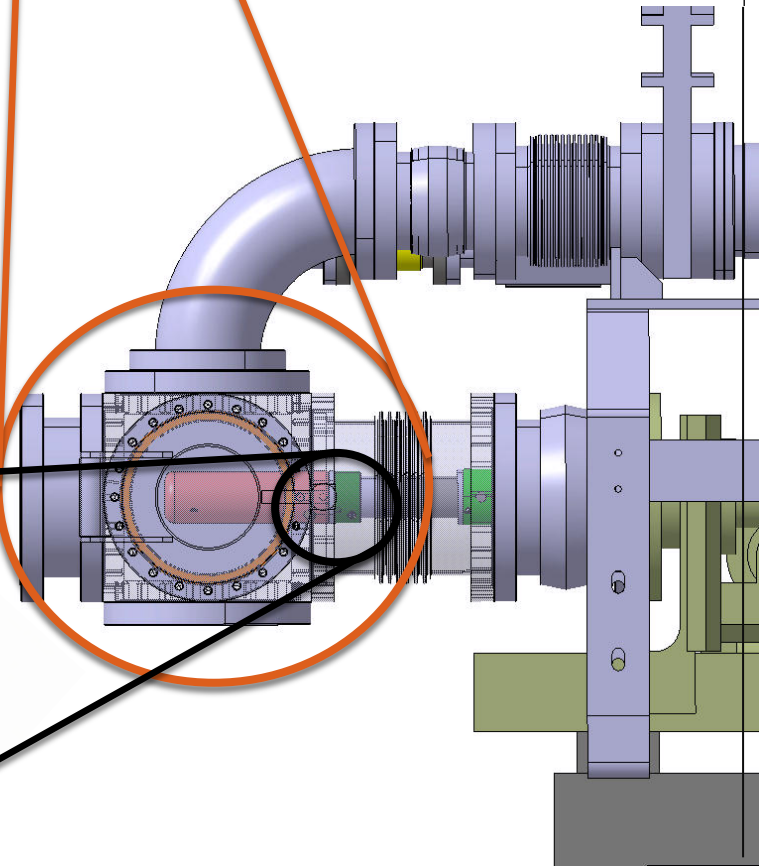

Image 6

MAST RP Linkbox

- 4 preamplifiers stored inside linkbox
- MAST will connect non terminated cable ends from preamplifiers to RP
- Bias supply and power supply cables to preamp will run into linkbox

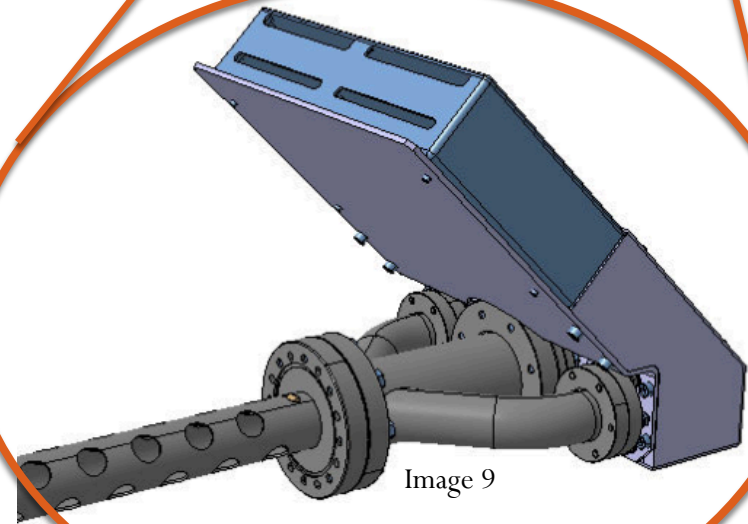
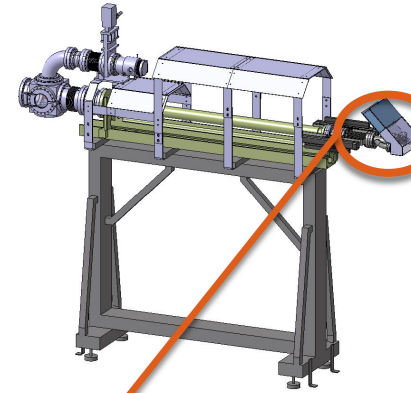

Image 9

MD05 Cubicle

- 4 Amplifiers
- CAMAC crate
 - 4 Adaptors
- 1 Computer
 - Network connection
- 1 Power Supply Unit
- 1 PCI extension box
 - Digital trigger input
- Ferrite cores

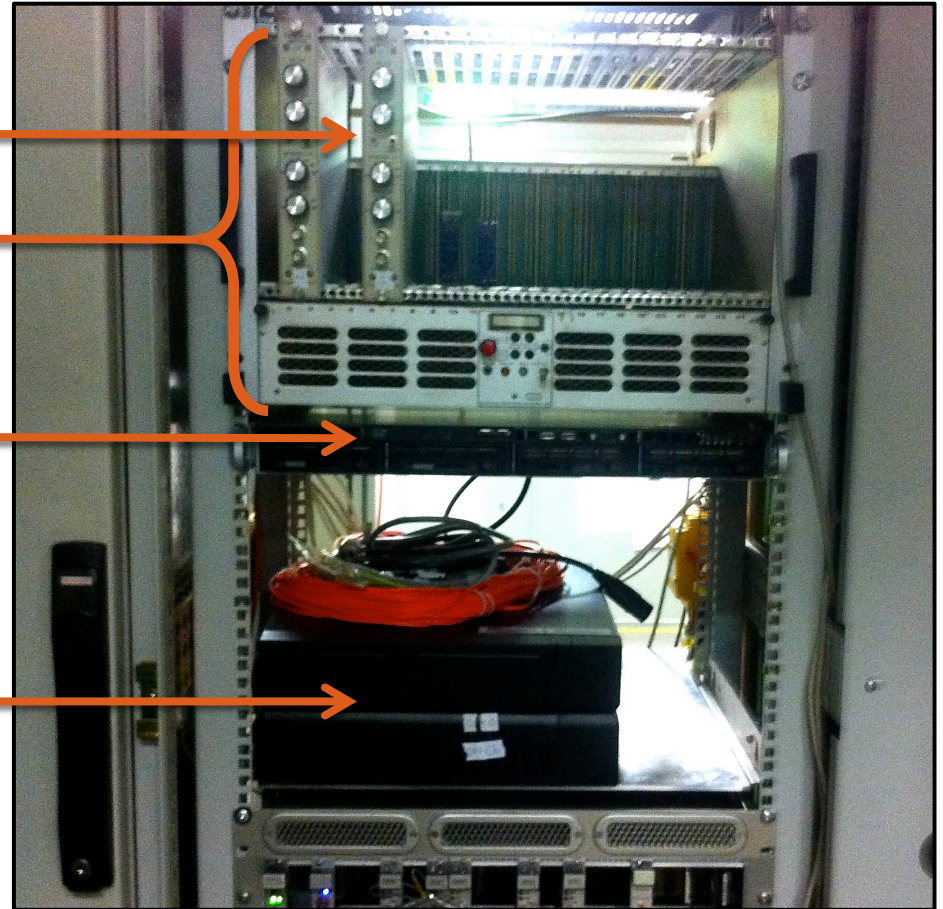
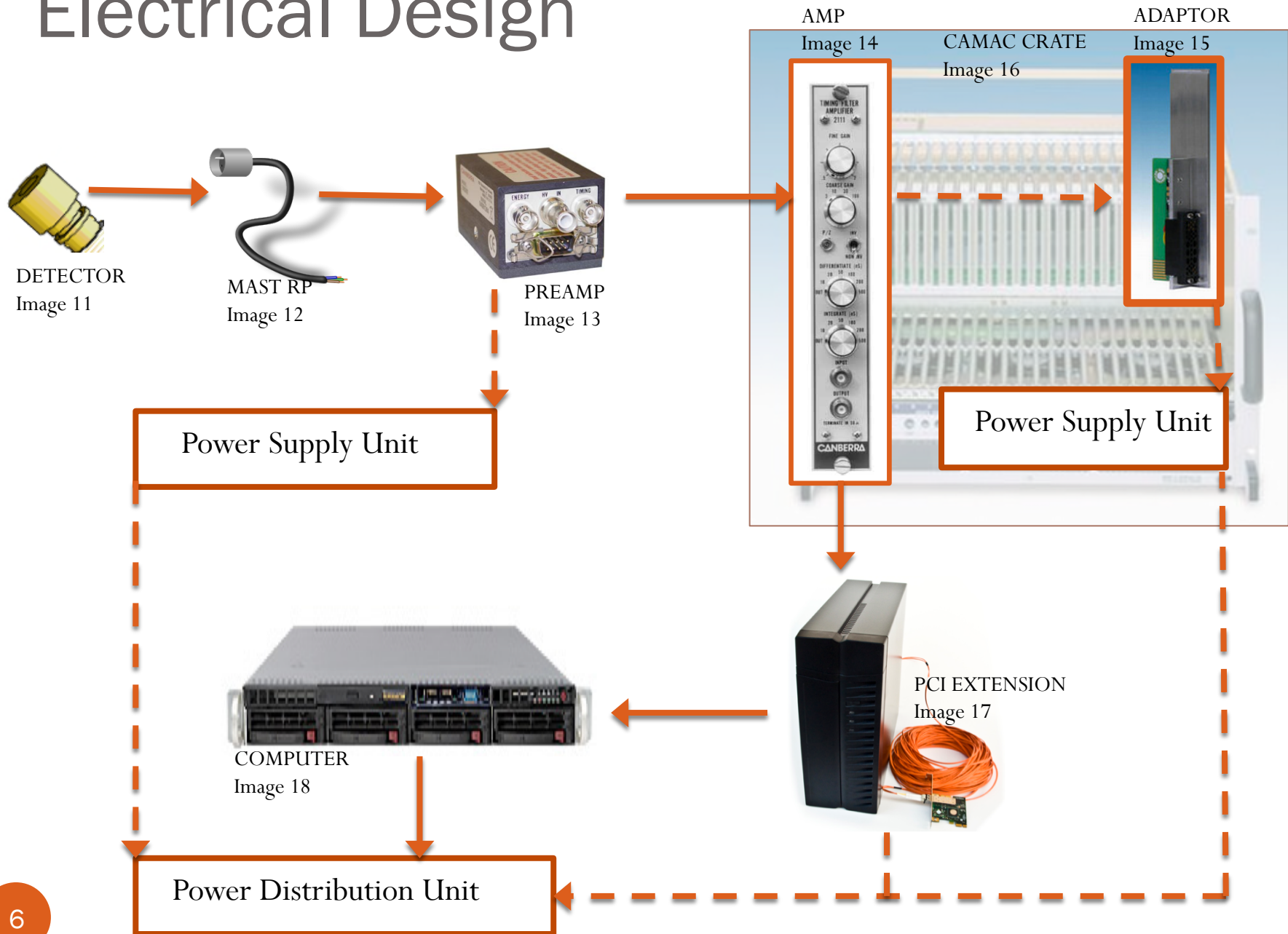

Image 10

Electrical Design



Cable Block Diagram

4 DATA CHANNELS

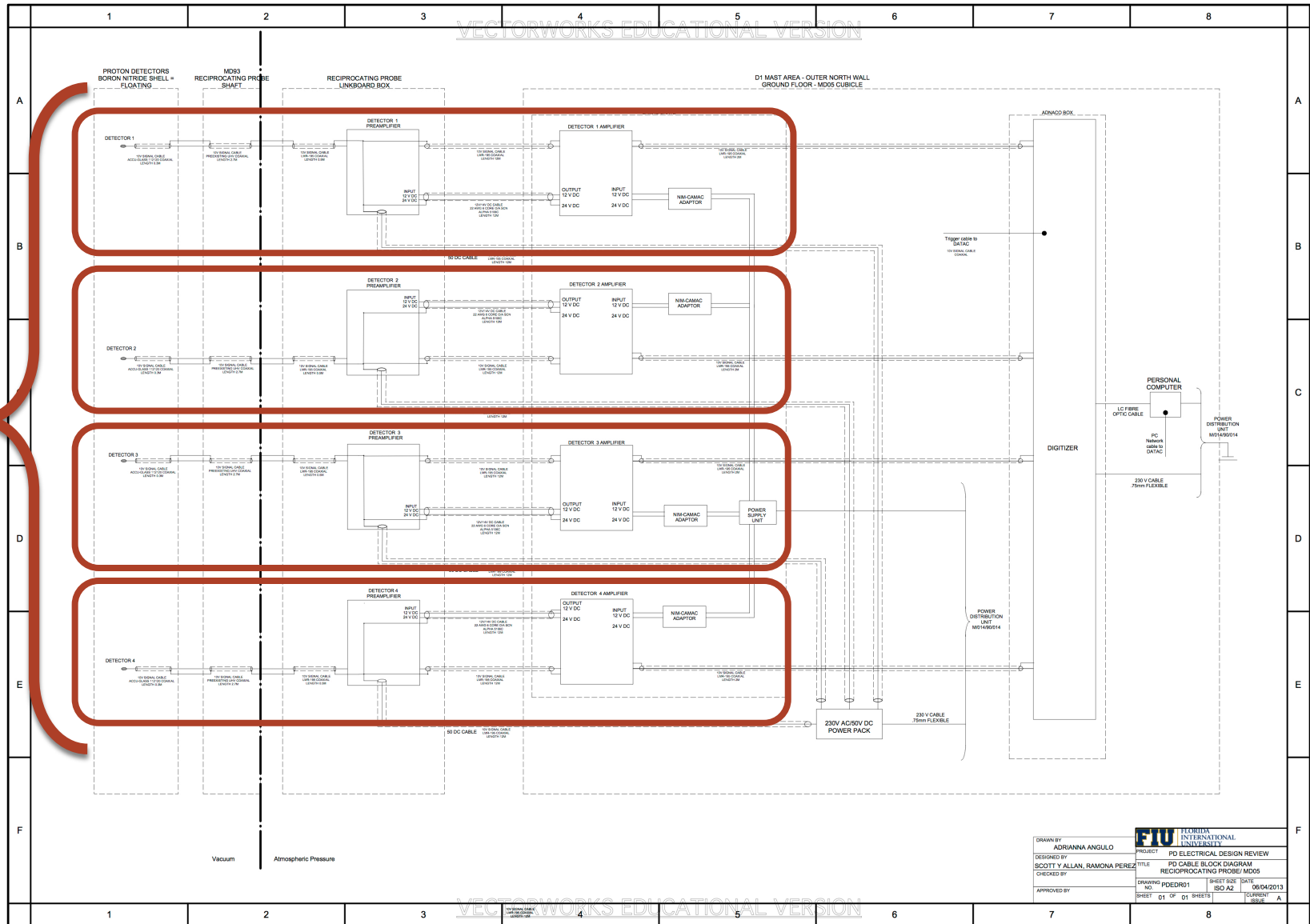

DRAWN BY ADRIANNA ANGULO	PROJECT PD ELECTRICAL DESIGN REVIEW
DESIGNED BY SCOTT Y ALLAN, RAMONA PEREZ	TITLE PD CABLE BLOCK DIAGRAM RECIPROCATING PROBE/ MD85
CHECKED BY	DRAWING NO PDEDR01
APPROVED BY	SHEET SIZE ISO A2
	DATE 06/04/2013
	CORRECTION ISSUE A

Cable Block Diagram

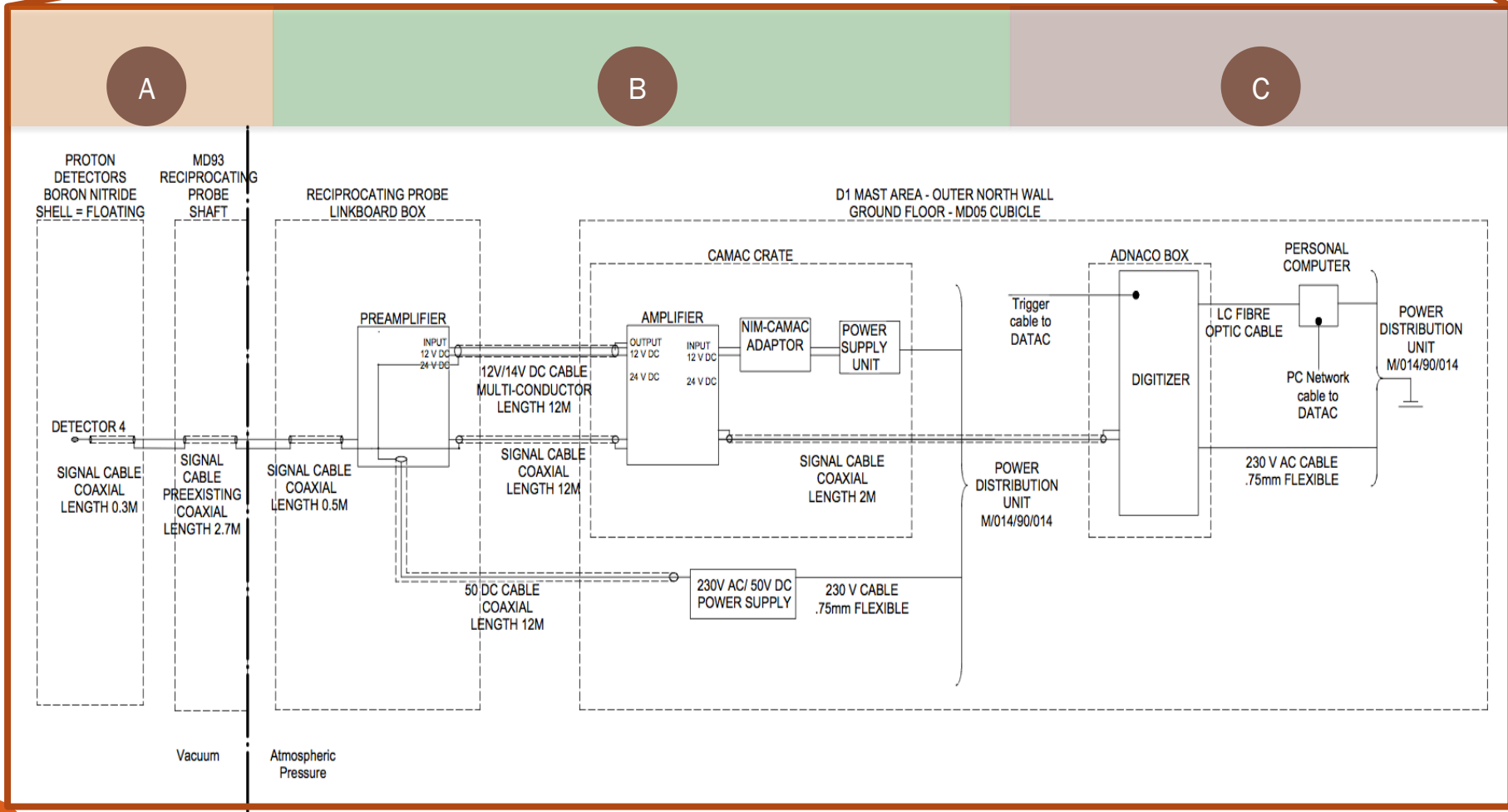
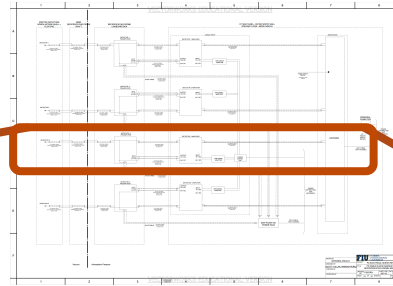

Cable Block Diagram

A

- Avoid ground loop concerns
- Electrically isolate Detector from RP body and ground at MD05 cubicle Vessel Earth
- Detector PEEK Insulator breakdown voltage 43.2kV

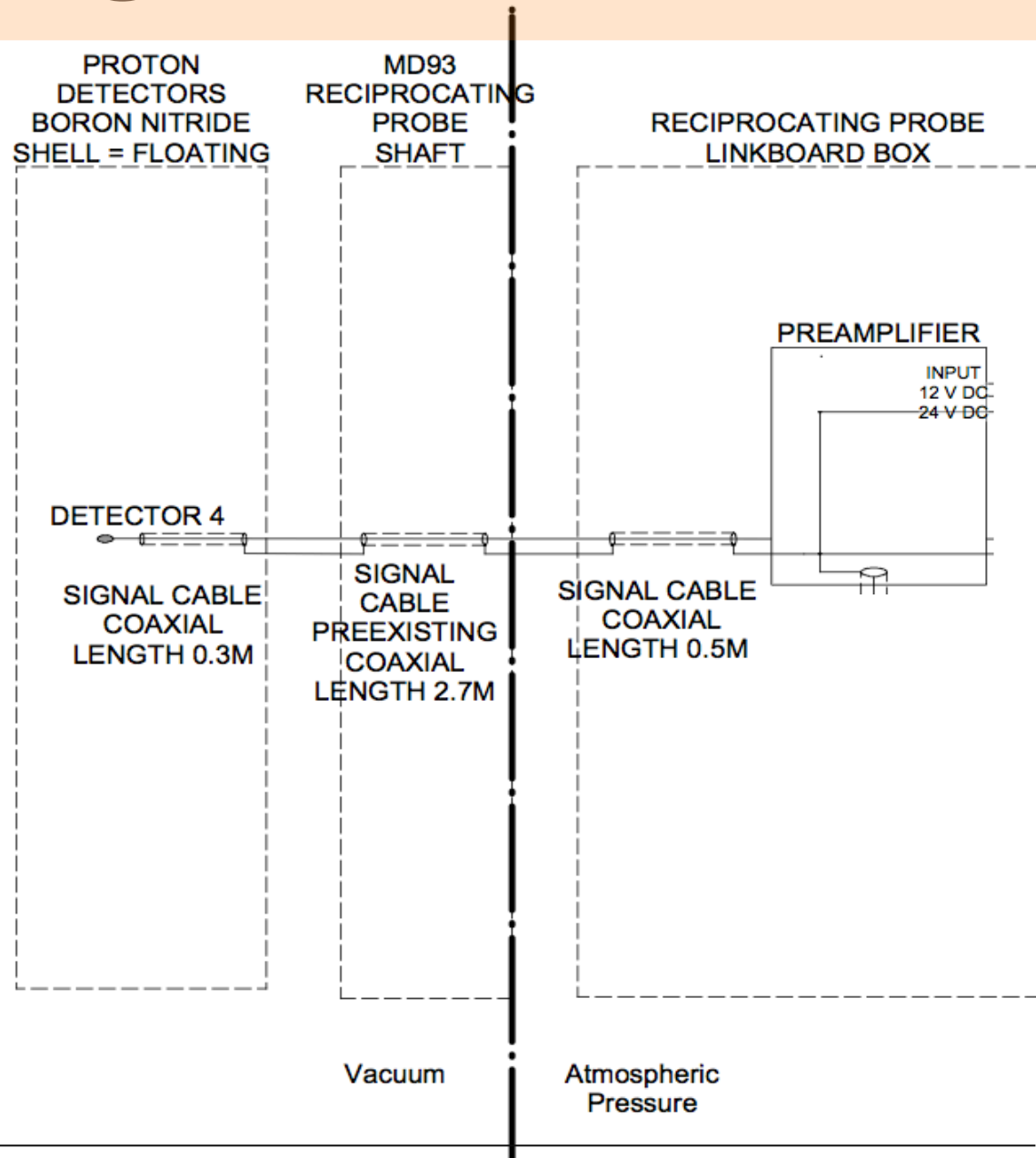

Cable Block Diagram A

CCFE DWG NO. M115-03-005

- Coaxial cable screens earthed to Diagnostic Earth through a single cable in the RP shaft
- Then:
 - Detector – Diagnostic Earth
 - Preamp/Amp – Vessel Earth

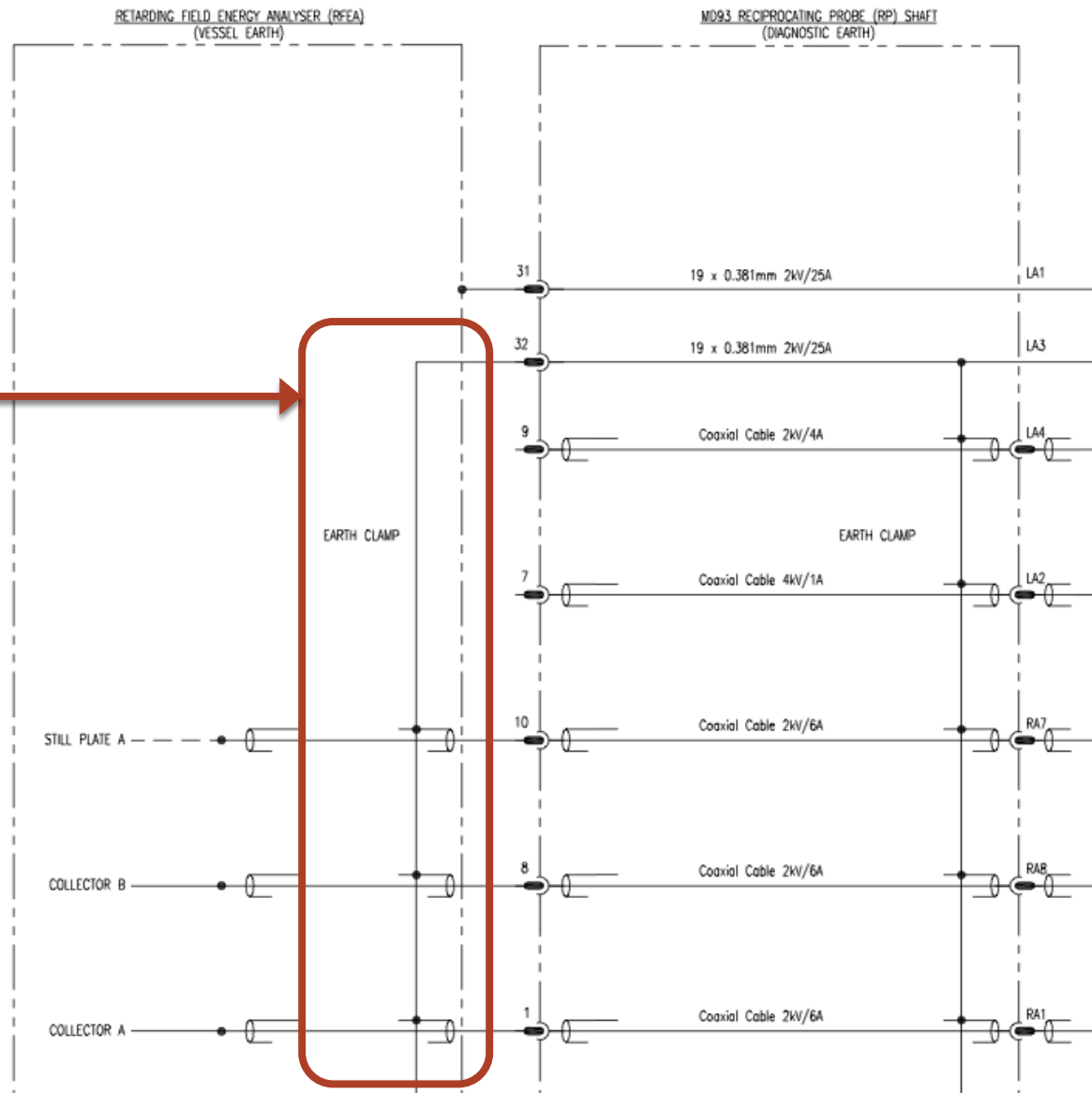

Cable Block Diagram

B

RECIPROCATING PROBE
LINKBOARD BOX

D1 MAST AREA - OUTER NORTH WALL
GROUND FLOOR - MD05 CUBICLE

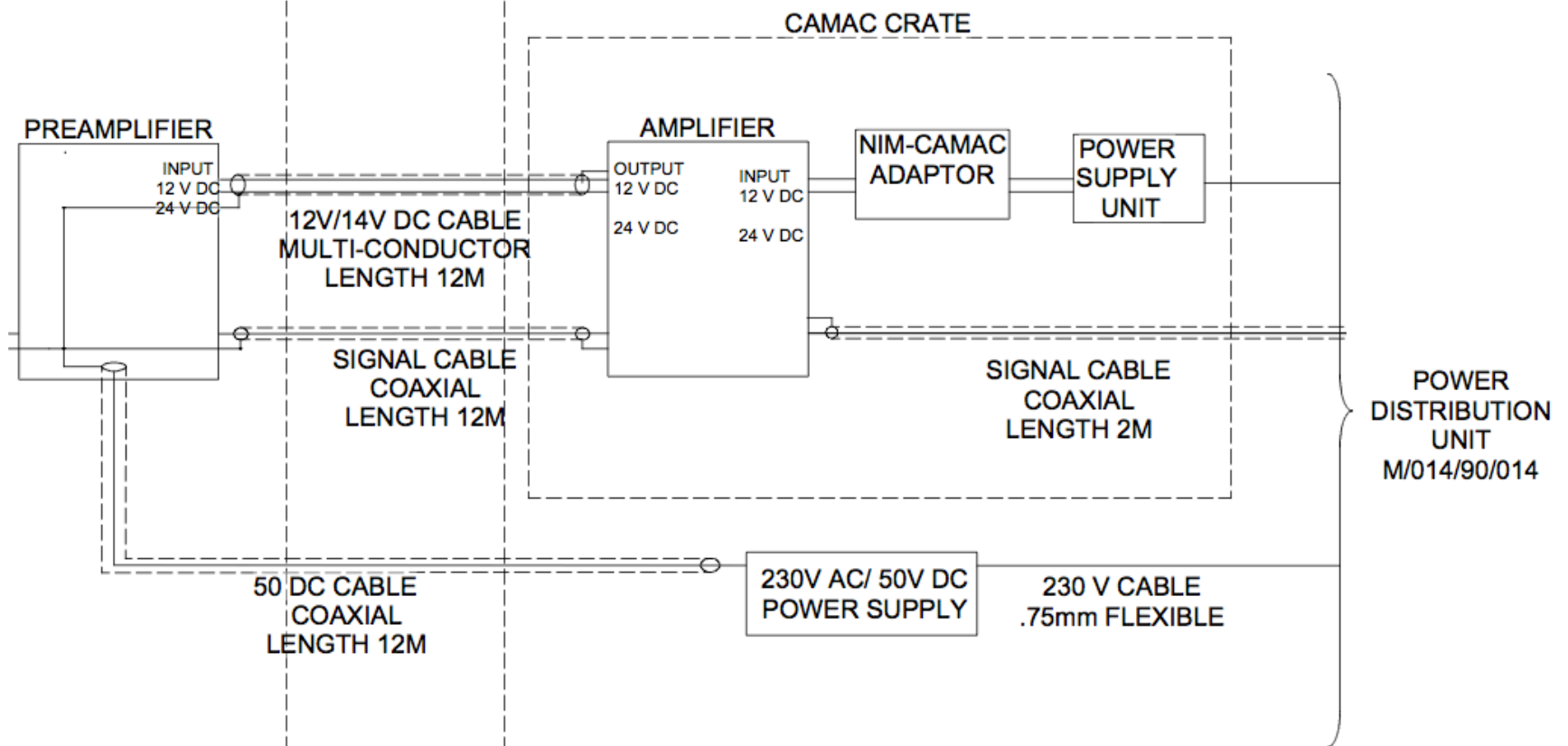

Cable Block Diagram



D1 MAST AREA - OUTER NORTH WALL
GROUND FLOOR - MD05 CUBICLE

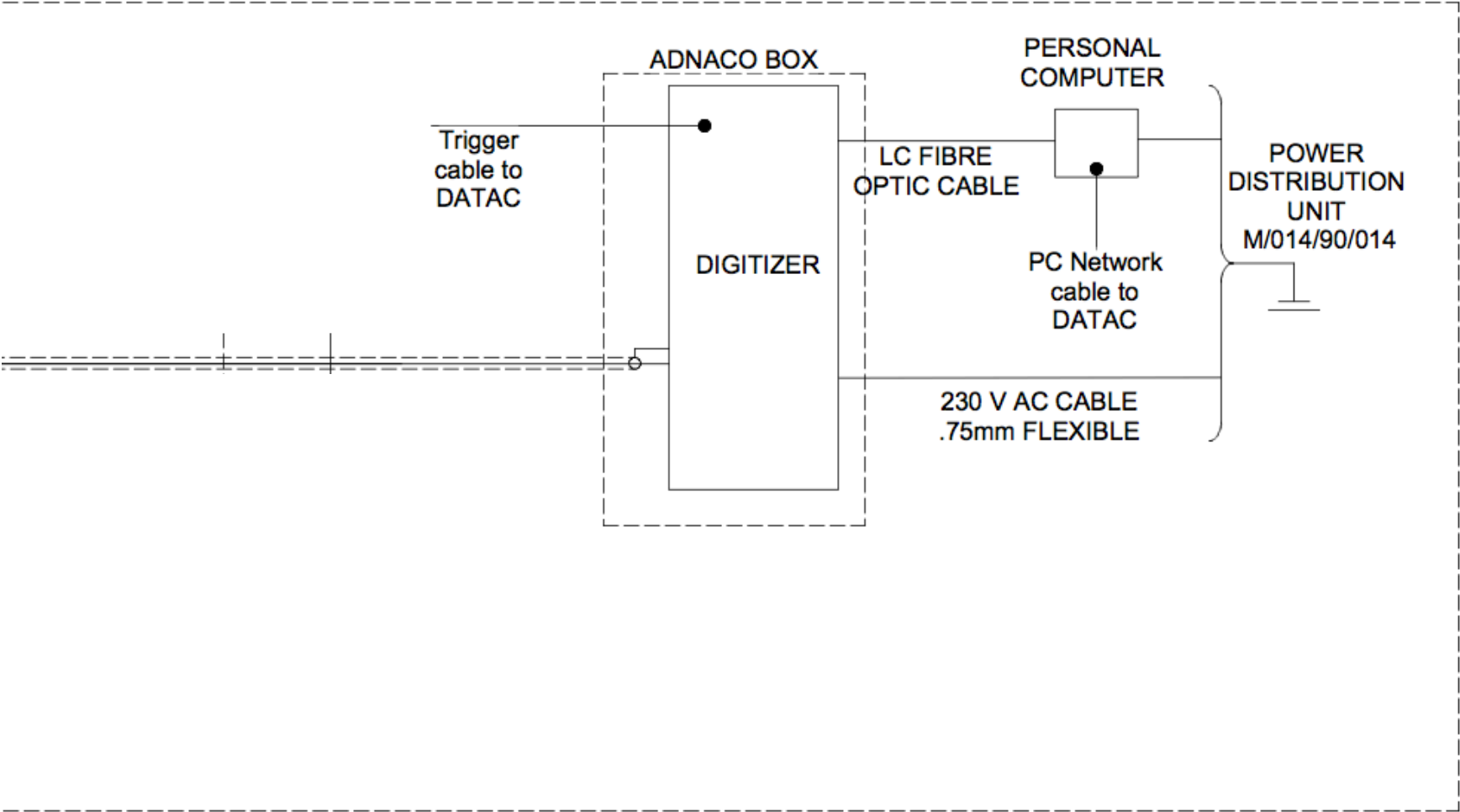

Data Collection Sequence Diagram

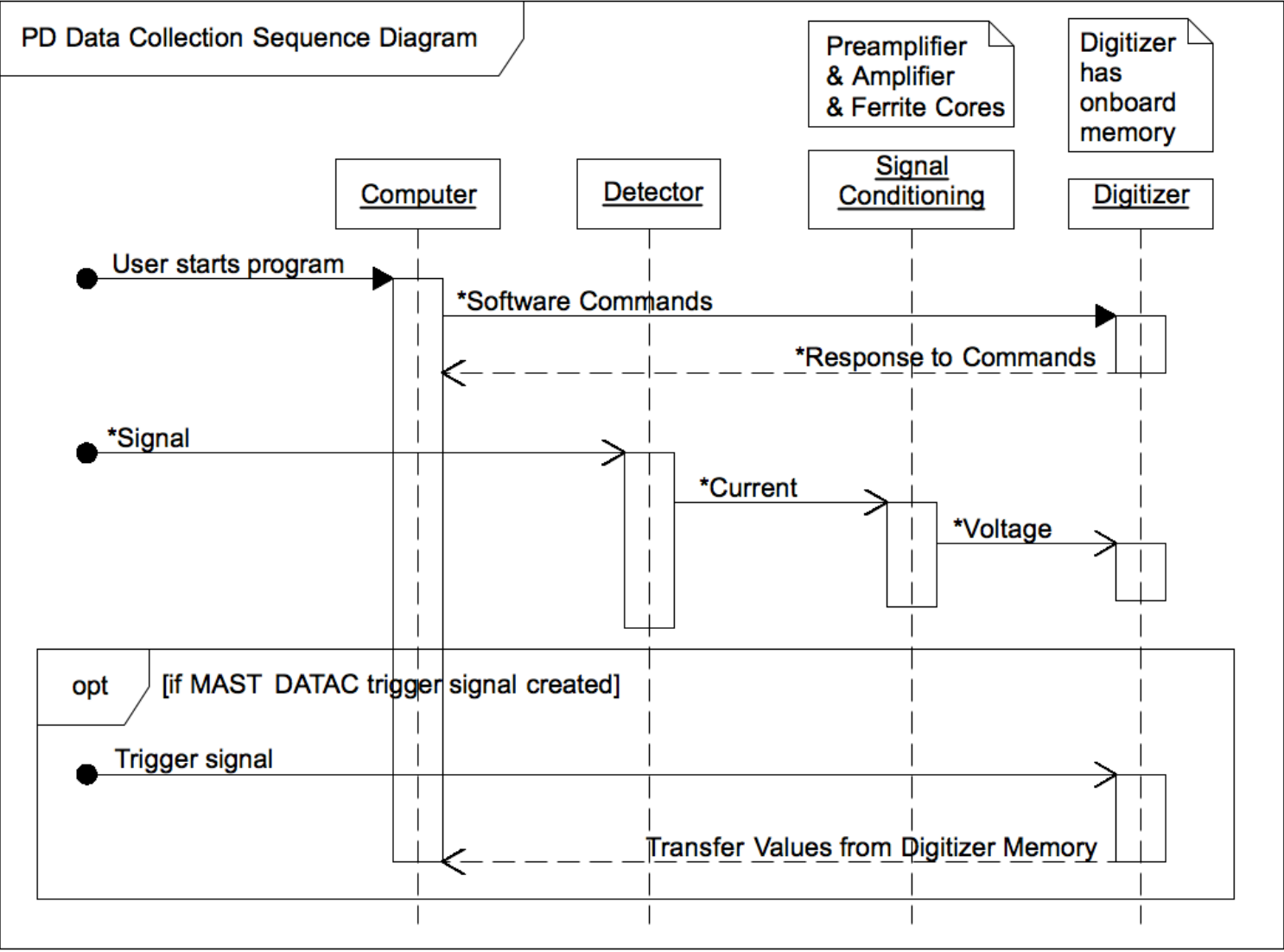

Power Requirements

ITEM	Volts (V)	Current (A)	Power (W)
ADNACO box**	12.7	22.5	285
AMPLIFIER	[+/-12V DC, +/-24V DC]	[.055, .170]	[1.3, 2]
COMPUTER**	12	27	330
POWER SUPPLY UNIT**	50	2	100
PREAMPLIFIER	[+/-12V DC, +/-24V DC]	[.03, .01]	[.1, .360]

**Compatible with mains power 200-240 V AC

Installation Requirements

- Tray work and cable routing to be performed by CCFE
 - Insulating wrap around cable connections to prevent contact with metallic surfaces
- The active area of the detectors can never to be touched
- Cable from detector to MAST RP to be connected to MAST RP electrical plug by CCFE
- Cable from MAST RP to preamplifier to be connected to MAST RP electrical plug by CCFE
- Moving of MAST RP (radial and rotational displacement) to be done by CCFE

Safety Requirements

- 50 V Power Supply Unit has SHV output connections
- Wait 5 minutes after turning off Power Supply Unit for preamplifiers before disconnecting preamplifiers
- All FIU personnel must be accompanied by a CCFE collaborator to enter the MAST test cell area
- All personnel must wear helmets in MAST test cell area

Timeline

DATE RANGE	GOALS
July 22 nd – 26 th 2013	<ul style="list-style-type: none">• PD Diagnostic arrives at CCFE• Bake part of PD diagnostic to be installed in MAST RP
July 29 th - August 2 nd 2013	<ul style="list-style-type: none">• Install PD Diagnostic onto MAST RP• Install cables• Install equipment in MD05
August 2 nd – 23 rd 2013	<ul style="list-style-type: none">• Onsite data collection
September 2 nd – 12 th 2013	<ul style="list-style-type: none">• Remote data collection
End of M9 Campaign	<ul style="list-style-type: none">• Uninstall PD Diagnostic• Ship back to FIU

References- Images

1. Assembled PD Total. CAD image created by Ramona Perez. 2013. PNG File.
2. Assembled PD cross section. CAD image created by Ramona Perez. 2013. PNG File.
3. Assembled PD transparent shell. CAD image created by Ramona Perez. 2013. PNG File.
4. Side View of Assembled MAST Reciprocating Probe. CAD image created by the Culham Centre for Fusion Energy's MAST Drawing Office. 2012. PDF File.
5. Scott Y. Allan. MAST Reciprocating Probe. Culham Centre for Fusion Energy. 2012. JPG File.
6. MAST Reciprocating Probe Access Cube. CAD image created by the Culham Centre for Fusion Energy's MAST Drawing Office. 2012. PDF File.
7. Side View of MAST Reciprocating Probe. CAD image created by the Culham Centre for Fusion Energy's MAST Drawing Office. 2012. PDF File.
8. MAST RP plug. CAD image created using CAD file provided by the Culham Centre for Fusion Energy's MAST Drawing Office. 2012. CAD image PNG File. CAD File IGS File.
9. Linkbox MAST Reciprocating Probe. CAD image created by the Culham Centre for Fusion Energy's MAST Drawing Office. 2012. PDF File.
10. Ramona Perez. MAST MD05 Cubicle. Culham Centre for Fusion Energy. 2013. JPG File.
11. PD Detector. CAD image created by Ramona Perez. PNG File.
12. Cable. Openclipart is original royalty free clipart, Images, Graphics, Templates, Icons, for unlimited commercial use on posters, presentations, greeting cards, coloring books illustrations, and design. Waived of all copyright and related or neighboring rights under the CC0 PD Dedication. PNG File.
13. Please ask for user manual, CANBERRA Model 2003BT Silicon Surface Barrier Detector Preamplifier.
14. Please ask for user manual, CANBERRA 2111 Timing Filter Amplifier.
15. Please ask for specifications sheet, CAMAC-NIM Power Adapter, W-IE-NE-R, Pein & Baus, BmbH.
16. Please ask for specifications sheet, CAMAC CERN-CE 300W, W-IE-NE-R, Pein & Baus, BmbH.
17. Please ask for user manual, ADNACO S2 Fiber Optic PCI Bus Extender.
18. Please ask for user manual, SuperMicro 50161 MTF 1U Rackmount Server.

PROTON DETECTOR (PD)

Electrical Design Review

