

# Decommissioning the Proton Detector: September to October 2013

Document written by Ramona V Perez.

## Returning Items to CCFE:

- NIM BIN and CAMAC crate in G.65 can be returned to lab in MAST lower compass area
- NIM to CAMAC crate adaptors can be returned to wherever they came from
- Mini cubicle needs to be removed from the G.65 lab (Martin Simmonds said to contact Neil Reed and ask him to return the mini cubicle to the rubbish)
- Half cubicle that was used for PD data collection needs to be returned to Nigel Thomas-Davies (after removing the yellow/ green grounding cables and bolts)
- The yellow/ green grounding cables can be either returned to the Electronics Lab (if they have use for them) or placed with extra materials in G.65
- The lock washers, nuts, and machine screws used with the yellow/ green grounding cables stay in G.65
- The blue Nuclear Ultra Cables can remain in G.65 for shipment at a later date
- The vacuum cables can remain in G.65 for shipment at a later date
- The 2 Boron Nitride Shells can remain in G.65 for shipment at a later date
- Any 50Ohm BNC terminators, BNC barrels, and BNC T's can be returned to the Electronics Lab (aside from yours from the red toolbox)

## Shipping Equipment to FIU:

- Call Rory Conway (D4 stores, 6477) to verify date to drop off equipment for packing (I will email you and Rory regarding the shipment date)
- Go through equipment checklist before taking to D4 stores
- Print out new 'To and From' Shipping papers to be taped to boxes (10 copies, attached later in document)
- Load equipment and 2 shipping boxes from G.65 onto cart and take to Rory Conway in D4 stores (he already has the box, packing materials, and packing instructions)
- Make sure Rory has equipment checklist/ item list and labels

## Other items to be shipped afterwards to FIU:

- Vacuum cables from LewVAC
- 2 BN shells
- Blue Nuclear Ultra cables
- Shoulder screws (quantity 3 to be removed when disassembling the PD probehead)
- Metal detector holder (used with source for testing)

Disassembling the PD probe head:

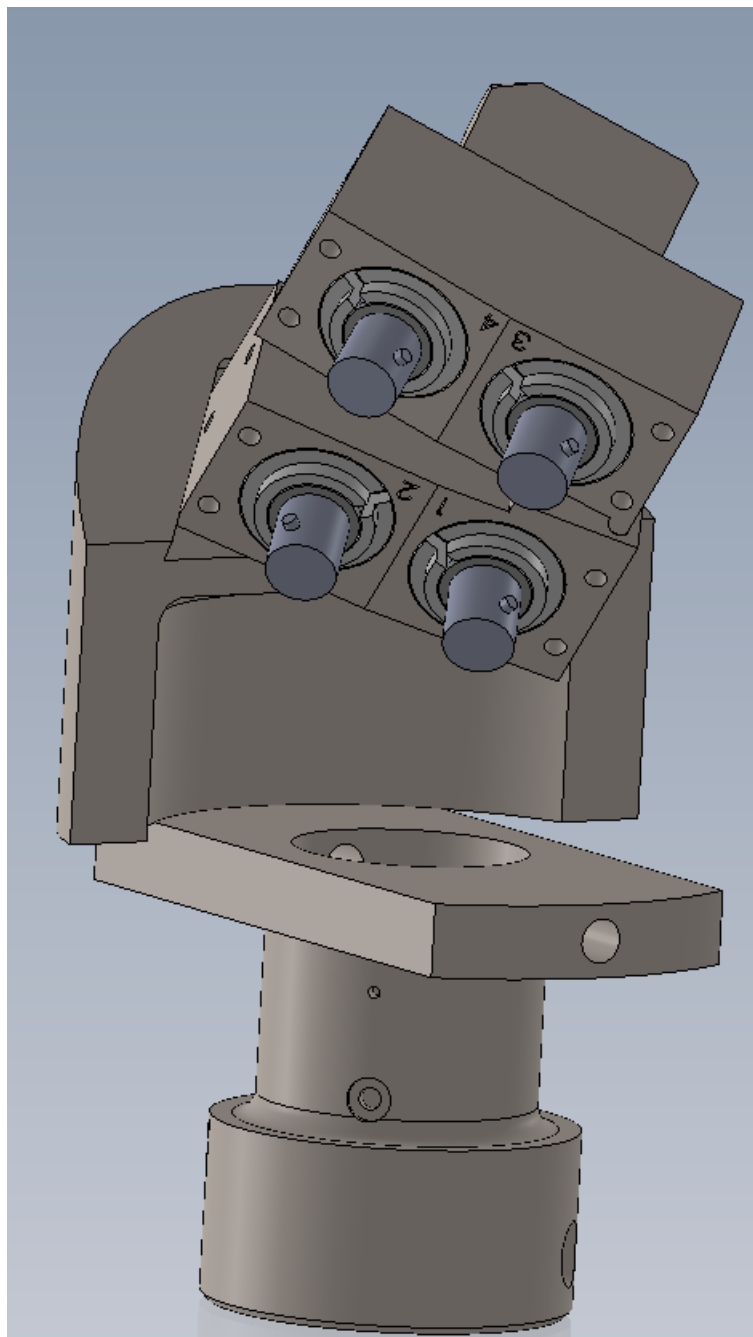

Figure 1: Please print this out to label the detector serial number next to each corresponding detector in the image. The detector near inscription 1 is ITEM 1, the detector near inscription 2 is ITEM 2, and so on. When removing items, please place them in their appropriate bags/ containers for shipping.

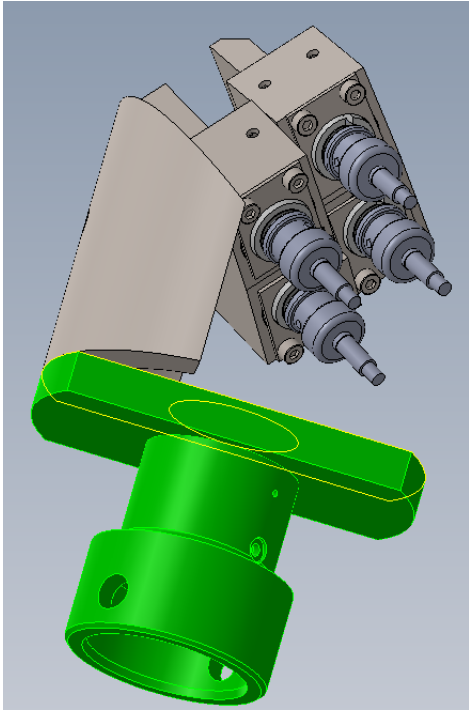

Figure 2: The MAST connector, ITEM 93, is highlighted in green.

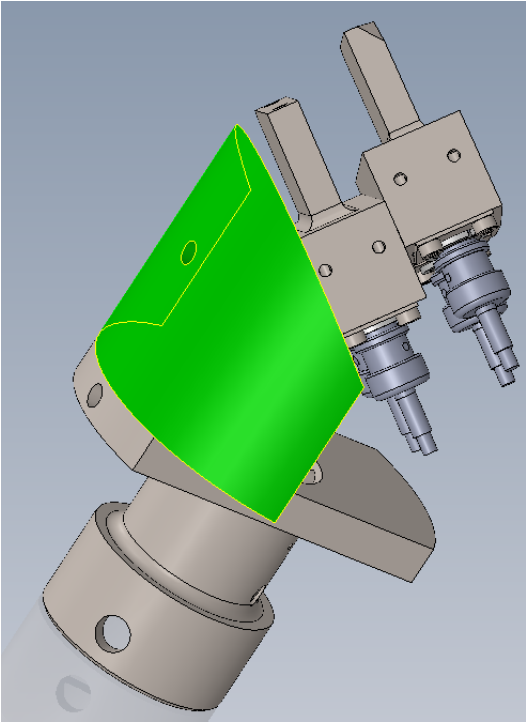

Figure 3: The connector, ITEM 92, is highlighted in green.

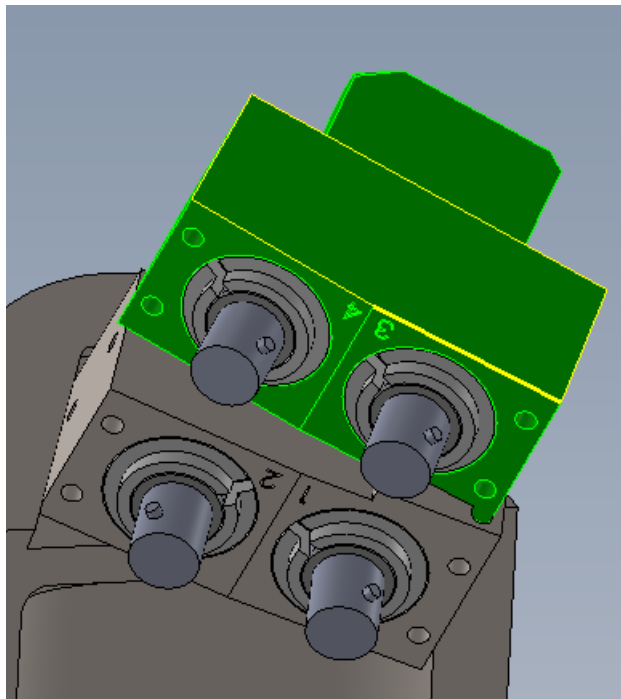

Figure 4: Module 1, ITEM 115, is highlighted in green. Notice numbers 3 and 4 inscribed next to the detectors.

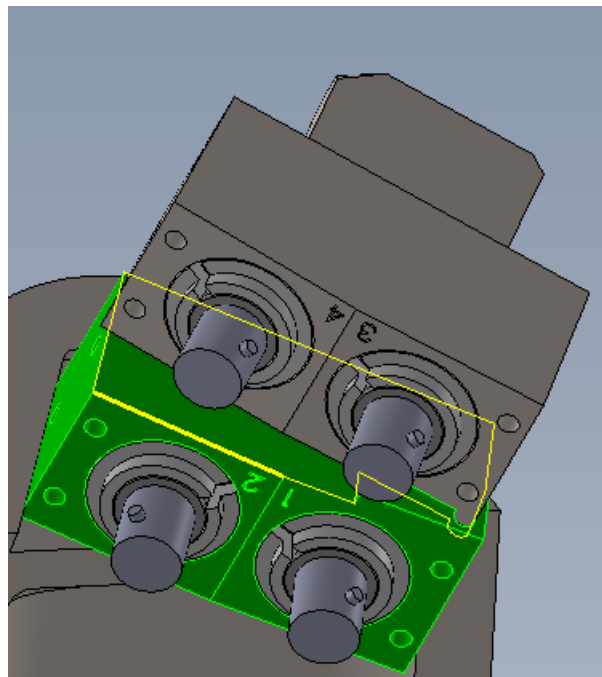

Figure 5: Module 2, ITEM 116, is highlighted in green. Notice numbers 1 and 2 inscribed next to the detectors.

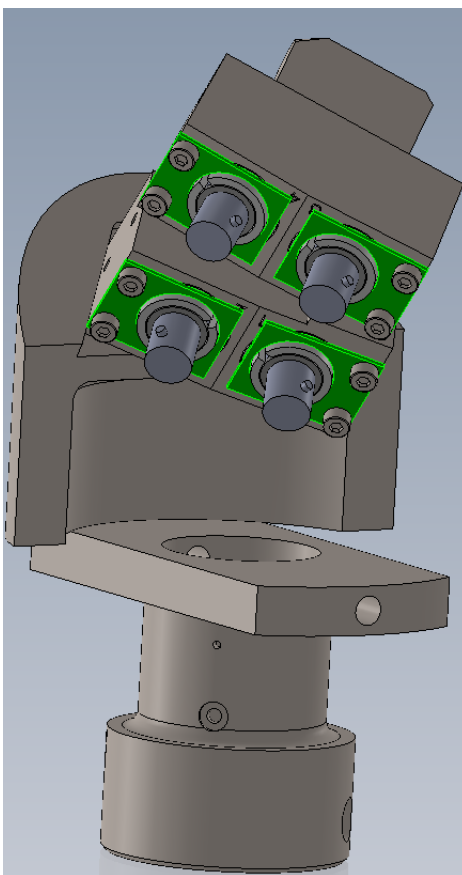

Figure 6: Bases, ITEMS 110-114, on modules are highlighted in green. They can be removed when you unscrew them. Remove only one base, one detector, and their corresponding parts at a time.

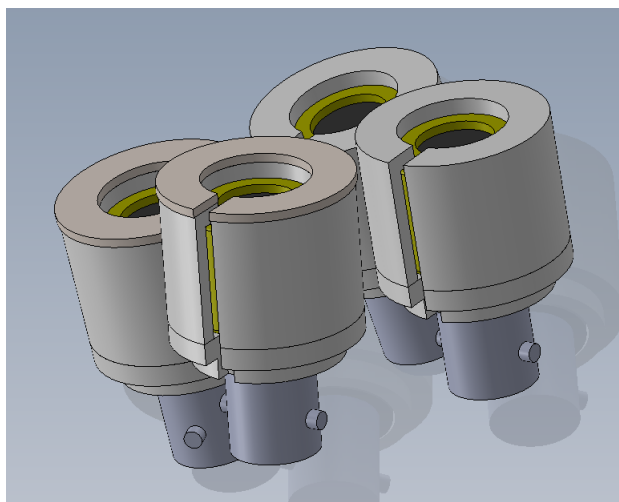

Figure 7: This is similar to how the detectors and corresponding parts look inside of the module. The difference is there is a piece of micron thick foil and shim shimstock on top of each detector. Please be careful when removing the detectors as the foil is sitting right on top of them and it is *extremely* fragile. The foil pieces can be placed in between the appropriate sheets in the small thin cardboard box which has a square container labeled ITEM 84; the white thin square cardboard box has fragile stickers. Please write the corresponding detector ITEM number (1-4) on the same sheet as each individual foil.

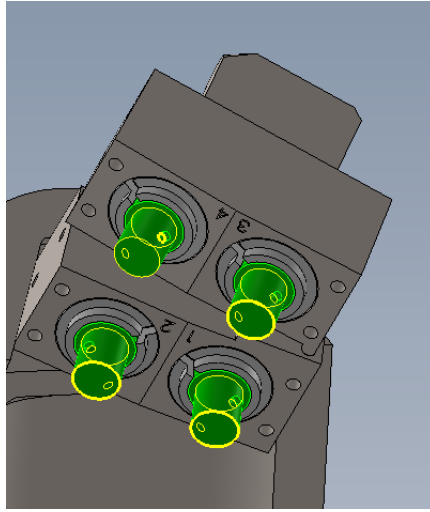

Figure 8: Bottom of detectors (the connectors of the detectors), ITEMS 1-4, are highlighted in green.

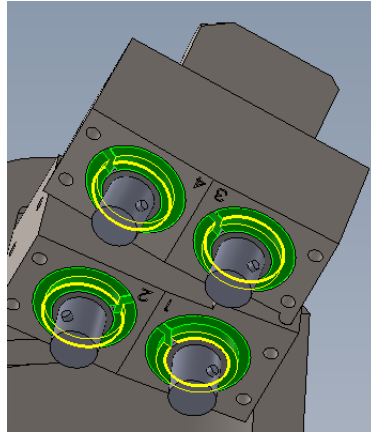

Figure 9: The peek bottoms, ITEMS 106-109, are highlighted in green. It is snugly attached to the connector on the detector. The detector should slowly be removed by its connector and once it is removed the peek bottom can be removed.

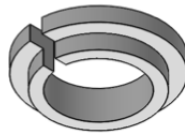

Figure 10: This is another image of the peek bottom.

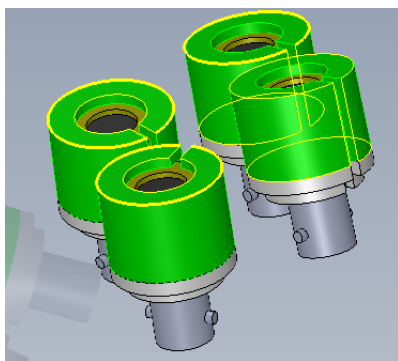

Figure 11: The peek sleeves, ITEMS 102-105, are highlighted in green. After the peek sleeves are removed, the white cover/ cap for the detector should immediately be placed over the active area of the detector to avoid damage.

It will be more convenient to leave the vacuum cables connected to the assembled RP electrical plug. This means that when they are wrapped the appropriate labels will have to be placed on the outer packaging. I will email Rory Conway in regards to this. Therefore if it is all packed intact, then the plug and cables packaging must have labels for: ITEM 117, ITEM 118, ITEM 121, ITEM 36, ITEMS 124-126.

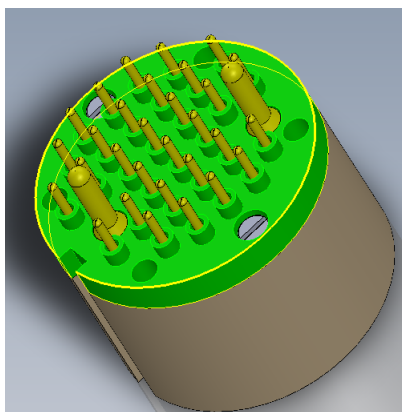

Figure 12: The pin retainer for the RP electrical plug, ITEM 117, is highlighted in green.

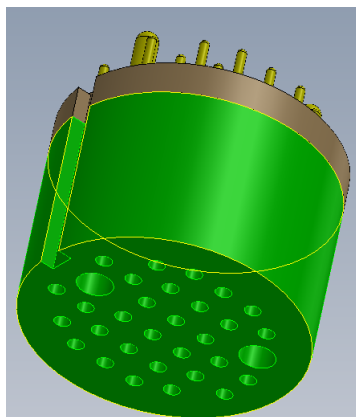

Figure 13: The pin retainer for the RP electrical plug, ITEM 118, is highlighted in green.

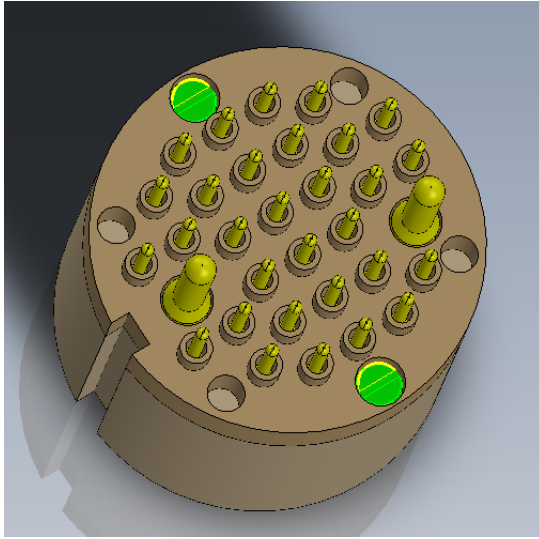

Figure 14: The cheesehead screws for the RP electrical plug.

The following attachments include: the new shipping labels to be printed, the ITEM list for shipping, and the cable block diagrams with ITEM numbers. Please send me an email if you have any questions.



**TO:**

WERNER BOEGLIN  
FLORIDA INTERNATIONAL UNIVERSITY  
11200 SW 8<sup>TH</sup> ST, CP204  
PHYSICS DEPARTMENT  
MIAMI, FLORIDA 33199

**FROM:**

IMPORT OFFICER RORY CONWAY  
UNITED KINGDOM ATOMIC ENERGY  
AUTHORITY  
BUILDING D4, CULHAM SCIENCE CENTRE  
ABINGDON, OXFORDSHIRE  
OX 14 3DB  
UNITED KINGDOM

List of Items for SLI Air-Sea Forwarders, Inc.

<b>SHIPPER/ USPPI:</b>	<b>NOTIFY PARTY/ CONSIGNEE:</b>	<b>United Kingdom Atomic Energy Authority's VAT Number:</b>	<b>SERVICE:</b>
Werner Boeglin	Import Officer Rory Conway	GB 570 1013 91 037	AIR
Florida International University (FIU)	United Kingdom Atomic Energy Authority		CONSOLIDATE
Physics Department, CP204	Building D4, Culham Science Centre		PREPAID
11200 SW 8TH ST	Abingdon, Oxfordshire, OX14 3DB		DOOR TO DOOR
Miami, FL 33199	United Kingdom		INSURANCE
Phone: 305-348-1711	Phone: +44 (0) 1235 466477		
<a href="mailto:boeglinw@fiu.edu">boeglinw@fiu.edu</a>	<a href="mailto:Rory.Conway@ccfe.ac.uk">Rory.Conway@ccfe.ac.uk</a>		

**SHIPMENT: Shipment to Destination July 19th 2013**

ITEM NO.	ITEMS IN BOX	QUANTITY	SCHEDULE B NUMBER	D/F/M	VALUE (\$)	MODEL	SERIAL/ PART NO.	FIU SERIAL NO.	WEIGHT (KG)	BOX 1	BOX 2		
1	detector: semiconductor device	4	8541.900.0000	D	1109	CU-014-050-100S/ det2	52-021K20	-	0.16	<b>DIMENSIONS</b>	<b>DIMENSIONS</b>		
2			8541.900.0000	D	1109	CU-014-050-100S/ det3	52-021K21	-	0.16			36 x22 x18 inches	36 x22 x18 inches
3			8541.900.0000	D	1109	CU-014-050-100S/ det4	52-015C22	-	0.16				
4			8541.900.0000	D	554	CU-014-050-100S/ det1	50-102R6	-	0.16				
5	preamplifier: electronic integrated circuit	4	8542.33.0000	D	1250	Canberra 2003BT / preamp1	13000310	-	0.2	<b>COMBINED</b>	<b>COMBINED</b>		
6			8542.33.0000	D	1320	Canberra 2003BT/ preamp4	13000733	-	0.2				
7			8542.33.0000	D	1320	Canberra 2003BT/ preamp2	13000722	-	0.2				
8			8542.33.0000	D	1320	Canberra 2003BT/ preamp3	13000734	-	0.2				
9	amplifier: electronic integrated circuit	4	8542.33.0000	D	1822	Canberra 2111/ amp4	13000144	-	0.9	<b>WEIGHT</b>	<b>VALUE</b>		
10			8542.33.0000	D	1769	Canberra 2112/ amp1	13000091	4980-US003644	0.9				
11			8542.33.0000	D	1822	Canberra 2111/ amp2	13000142	-	0.9				
12			8542.33.0000	D	1822	Canberra 2112/ amp3	13000153	-	0.9				
13	computer	1	8471.41.0150	D	1221.24	Supermicro 813M-2	5016I-MTF	-	17.2	<b>OF BOXES (KG)</b>	<b>OF BOXES (\$)</b>		
14	digitizer***	1	8471.60.7000	D	8639.10	NI PCI-5105	ED9174	4980-US003575	0.474				
15	PCI expansion system	1	8471.49.0000	D	997	ADNACO-S2-50	ADNACO-S2-50	4980-US003567	6.1			80	39565.11
16	fiber optic cable**	1	8544.70.0000	D	**	**	**	**	1				
17	power supply unit	1	8504.40.6007	D	1457.54	FIU Four Channel Output	FIU Power Supply 1	-	3.4				
18	LabVIEW Full Development System Software	1	8523.49.2010	D	649.75	776670-35	M74X67418	-	0.06				
19	multi conductor cable assembly	4	8544.42.0000	D	109.15	Alpha Wire 5106C/ power#1	A5106C	-	0.24				
20			8544.42.0000	D	109.15	Alpha Wire 5106C/ power#2	A5106C	-	0.24				
21			8544.42.0000	D	109.15	Alpha Wire 5106C/ power#3	A5106C	-	0.24				
22			8544.42.0000	D	109.15	Alpha Wire 5106C/ power#4	A5106C	-	0.24				
23	coaxial cable assembly	4	8544.20.0000	D	33.75	LMR-195 BNC/ 12mA	R195-BMBM-12M	-	0.36				
24			8544.20.0000	D	33.75	LMR-195 BNC/ 12mB	R195-BMBM-12M	-	0.36				
25			8544.20.0000	D	33.75	LMR-195 BNC/ 12mC	R195-BMBM-12M	-	0.36				
26			8544.20.0000	D	33.75	LMR-195 BNC/ 12mD	R195-BMBM 12M 0213	-	0.36				
27	coaxial cable assembly	1	8544.20.0000	D	17.6	LMR-195 12m SHVM-SHVM cable	R195	-	0.36				
28	coaxial cable assembly	4	8544.20.0000	D	22.50	LMR-195 BNC/ 2mA	R195-BMSBM-2M	-	0.06				
29			8544.20.0000	D	22.50	LMR-195 BNC/ 2mB	R195-BMSBM-2M	-	0.06				
30			8544.20.0000	D	22.50	LMR-195 BNC/ 2mC	R195-BMSBM-2M	-	0.06				
31			8544.20.0000	D	22.50	LMR-195 BNC/ 2mD	R195-BMSBM-2M	-	0.06				
32	coaxial cable assembly	4	8544.20.0000	D	9	LMR-195 BNC/ 0.5mA	R195-BLKBM-0.5M	-	0.015				
33			8544.20.0000	D	9	LMR-195 BNC/ 0.5mB	R195-BLKBM-0.5M	-	0.015				
34			8544.20.0000	D	9	LMR-195 BNC/ 0.5mC	R195-BLKBM-0.5M	-	0.015				
35			8544.20.0000	D	9	LMR-195 BNC/ 0.5mD	R195-BLKBM-0.5M	-	0.015				

36,124-126	coaxial cable assembly	4	8544.20.0000	D	95	TYP25-15' (20" bnc-terminated)	112129	-	0.045
37	coaxial cable assembly	2	8544.20.0000	D	34.30	RG174 SMB-LEMO/ triggerA	RG174-LEMO	-	0.036
38			8544.20.0000	D	34.30	RG174 SMB-LEMO/ triggerB	RG174-LEMO	-	0.036
39	coaxial cable spool 1	1	8544.20.0000	D	48	100ft cable spool	LMR-195	-	0.915
40	coaxial cable spool 2	1	8544.20.0000	D	62.40	130ft cable spool	LMR-195	-	1.188
41-48	electrical connectors	8	8544.42.0000	D	5.97	SMB male	99H5336	-	0.16
49-64	electrical connectors	16	8544.42.0000	D	1.41	BNC male	99H4267	-	0.32
65-66	electrical connectors	2	8544.42.0000	D	16.45	SHV male	09WX3993	-	0.04
67-82	ferrite cores snap-ons	16	8547.90.0040	D	1.98	Newark ferrite core 6.3mm	73K6078	-	0.416
83	aluminum foil pack 1	1	7607.19.0000	D	614	AL000271 Aluminum ( Al ) Foil	702-857-87	-	0.001
84	aluminum foil pack 2	1	7607.19.0000	D	250	AL000210 Aluminum ( Al ) Foil	304-353-86	-	0.001
85	Shim stock roll	1	7219.90.0000	D	26.09	316SS Shim Stock Roll	9548K13	-	0.2
86-91	316SS piece	6	8487.90.0080	D	17.29	BRACKET	PD22ITEM2	-	0.018
92	316SS piece	1	8487.90.0080	D	1143	CONNECTOR	PD22ITEM4	-	0.64
93	316SS piece	1	8487.90.0080	D	1405	MAST_CONNECTOR	PD22ITEM5	-	0.49
94-101	316SS piece	8	8487.90.0080	D	36.20	WASHER	PD22ITEM7	-	0.016
102-105	316SS piece	4	8487.90.0080	D	17.50	PEEK SLEEVE	PD22ITEM8	-	0.008
106-109	316SS piece	4	8487.90.0080	D	17.50	PEEK BOTTOM	PD22ITEM9	-	0.004
110-114	316SS piece	5	8487.90.0080	D	61.35	BASE	PD22ITEM10	-	0.01
115	316SS piece	1	8487.90.0080	D	1385.50	MODULE A	PD22ITEM11	-	0.23
116	316SS piece	1	8487.90.0080	D	1385.50	MODULE B	PD22ITEM12	-	0.23
117	MAST RP pin retainer	1	8536.69.4020	D	350	MAST RP pin retainer	RPPLUGRETAINER	-	0.001
118	MAST RP pin housing	1	8536.69.4020	D	350	MAST RP pin housing	RPPLUGHOUSING	-	0.02
119	Machine Screw pack1	1	7318.15.2000	D	6.57	316SS Socket Head Cap Screws	92290A118	-	0.052
120	Machine screw pack2	1	7318.15.2000	D	10.90	316SS Flat Head Socket Cap Screws	93395A366	-	0.157
121	Machine Screw pack3	1	7318.15.2000	D	11.1	Cheese Head Machine Screws	91613A036	-	0.02
122	aluminum box	1	8542.90.0000	D	17.55	aluminum enclosure case	46F6038	-	0.5kg
123	electrical cable shielding	1	8543.90.9000	D	180	Tin/Cu braided sleeving	TUB BR25/32 TC A2176	-	13.6

\*\*included as a part of the PCI expansion system

\*\*\*installed inside of PCI expansion system

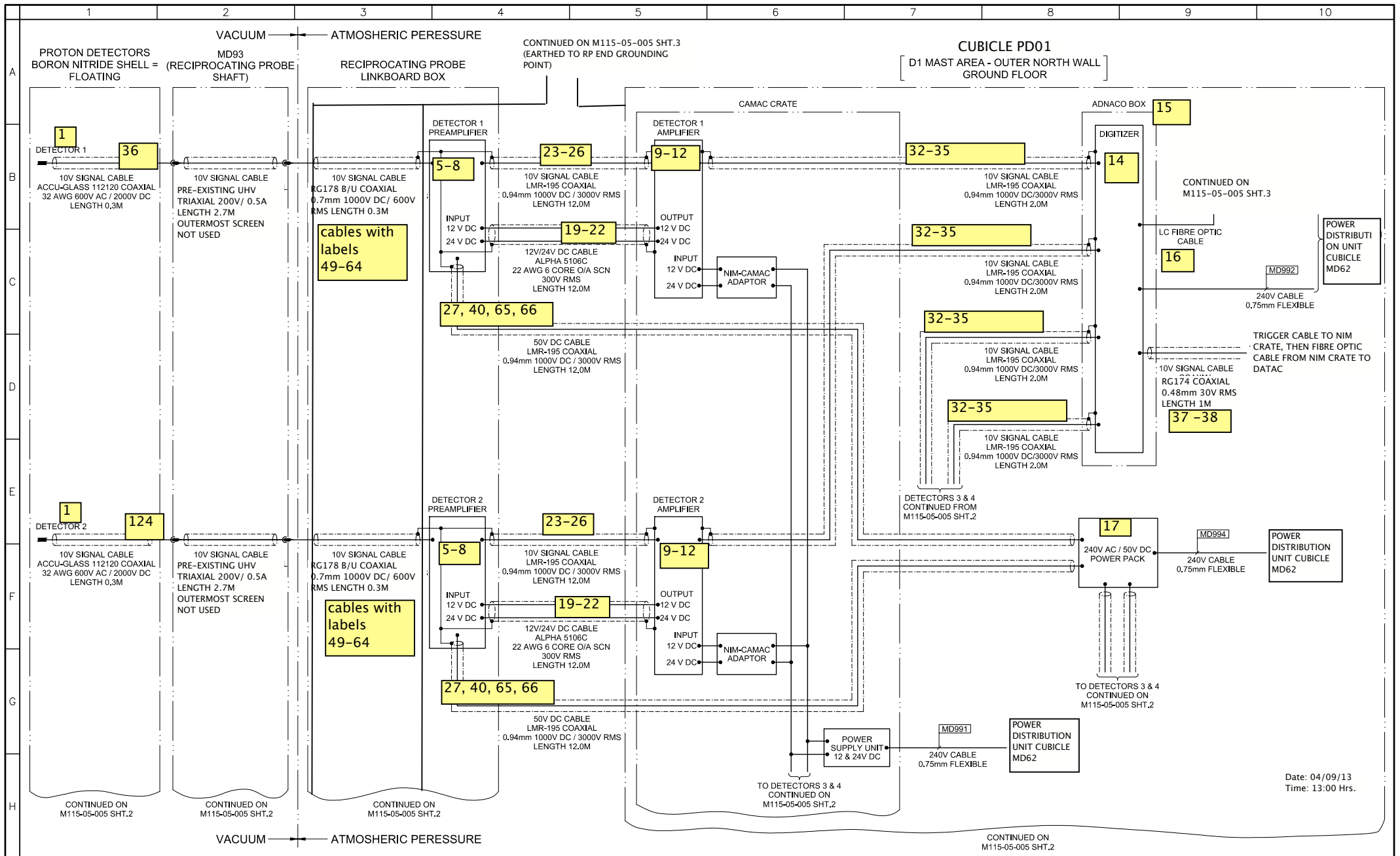

Date: 04/09/13  
Time: 13:00 Hrs.

Document created using * AutoCAD *									
Do not modify by hand									
NOT FOR PUBLICATION This Document shall not without prior written consent from CCFE be copied in whole or in part or used for any purpose other than that for which it is supplied									
A.O	02/07/13	FIRST ISSUE	AP						
Issue	Date	Status/Modification	Drawn	Checked	Approved	Mod. No.			

Dimensions in mm unless otherwise stated	Reference Drawing:
THIS DOCUMENT PRINTED : Date: 04/09/13 Time: 13:00 Hrs.	Assembly Procedure: CADfile: M11505005.1

TITLE:  
**RECIPROCATING PROBE  
PROTON DETECTION NOISE TESTS  
(FOUR DETECTOR SCHEME)  
BLOCK CABLE DIAGRAM**

	DWG. No.	<b>M115-05-005</b>	Issue
	Quality Class:		Sheet No. 1 of 3 Sheets

CCFE  
CULHAM CENTRE FOR FUSION ENERGY

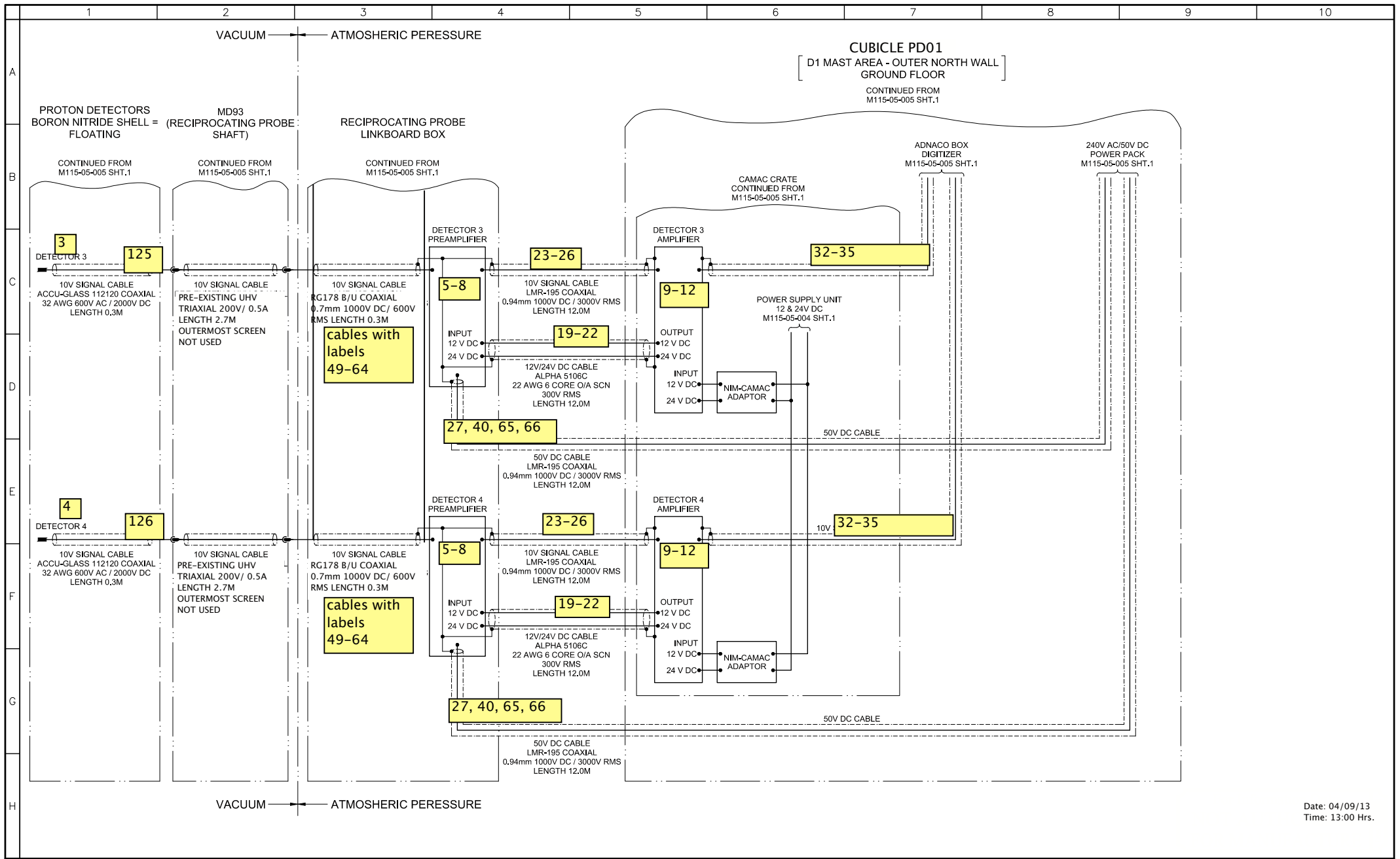

Date: 04/09/13  
Time: 13:00 Hrs.

Document created using  
\* AutoCAD \*  
Do not modify by hand

**NOT FOR PUBLICATION**  
This Document shall not without prior written consent from CCFE be copied in whole or in part or used for any purpose other than that for which it is supplied

Issue	Date	Status/Modification	Drawn	Checked	Approved	Mod. No.
A.0	02/07/13	FIRST ISSUE	AP			

Dimensions in mm unless otherwise stated	Reference Drawing:
THIS DOCUMENT PRINTED : Date: 04/09/13 Time: 13:00 Hrs.	Assembly Procedure: CADfile: M11505005.2

**TITLE:**  
**RECIPROCATING PROBE**  
**PROTON DETECTION NOISE TESTS**  
**(FOUR DETECTOR SCHEME)**  
**BLOCK CABLE DIAGRAM**

United Kingdom Atomic Energy Authority

DWG. No. **M115-05-005**

Quality Class: Sheet No. 2 of 3 Sheets

**CCFE**  
CULHAM CENTRE FOR FUSION ENERGY



Issue **A.0**

Sheet No. 2 of 3 Sheets **A3**

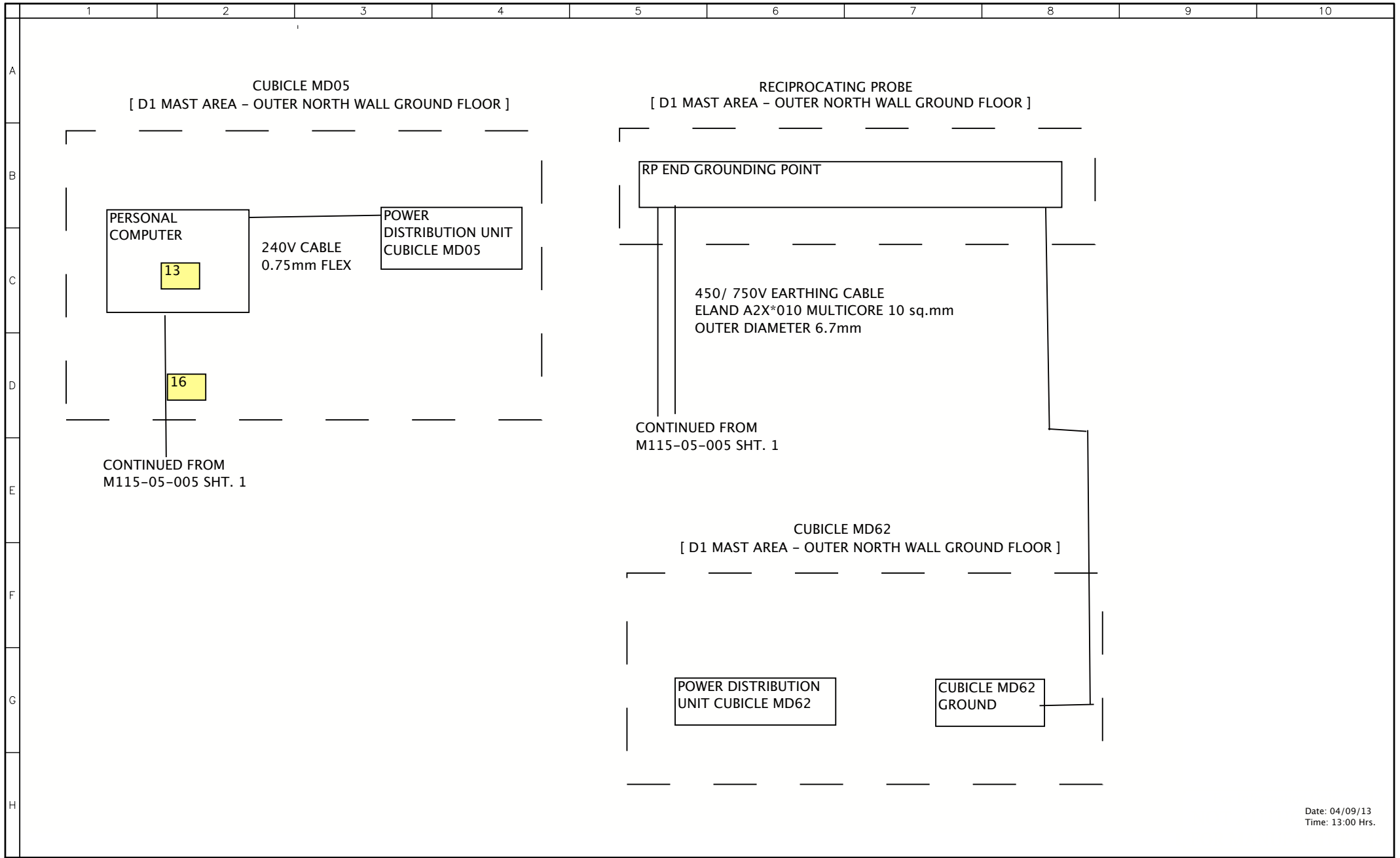
Ref: EDS-A3L/JET/170107/mv.



Date: 04/09/13  
Time: 13:00 Hrs.

Document created using * AutoCAD * Do not modify by hand																									
NOT FOR PUBLICATION This Document shall not without prior written consent from CCFE be copied in whole or in part or used for any purpose other than that for which it is supplied		A.0 02/07/13		FIRST ISSUE		AP						THIS DOCUMENT PRINTED : Date: 04/09/13 Time: 13:00 Hrs.		Reference Drawing: Assembly Procedure: CADfile: M11505005.2		TITLE: <b>RECIPROCATING PROBE PROTON DETECTION NOISE TESTS (FOUR DETECTOR SCHEME) BLOCK CABLE DIAGRAM</b>				 United Kingdom Atomic Energy Authority		 CULHAM CENTRE FOR FUSION ENERGY		DWG. No. <b>M115-05-005</b> Issue A.0	
Issue		Date		Status/Modification		Drawn		Checked		Approved		Mod. No.		Quality Class:		Sheet No. <b>3</b> of <b>3</b> Sheets		A3		Ref: EDS-A3L/JET/170107/mv.					