

Florida International University
Department of Physics Miami, Florida

Dissertation Proposal
September 27th, 2012

Title

A charged fusion product diagnostic for a spherical tokamak.

Candidate

Ramona Leticia Valenzuela Perez

Committee Members

Werner Boeglin, Committee Chair, Professor, FIU Department of Physics
Douglass Darrow, Principal Research Physicist, Princeton Plasma Physics Laboratory
Oren Maxwell, Professor, FIU Department of Physics
Jorge Rodriguez, Assistant Professor, FIU Department of Physics
Michael Sukop, Associate Professor, FIU Department of Earth and Environment

A Charged Fusion Product Diagnostic for a Spherical Tokamak

1 Introduction

1.1 Background

An increasingly technological society motivates research supporting future fusion energy production facilities. A deeper understanding of the physics of a plasma (a hot ionized gas) and nuclear fusion reactions is necessary to make fusion energy production a viable alternative energy source. The sun, for example, has plasma temperatures up to 10^7 Kelvin (K).[1, p. 13] While this massive star can rely on gravitational forces to confine its plasma, scientists have had to take up the challenge of confining plasmas of temperatures greater than the sun in our laboratories, a task greatly inconvenienced by the fact that plasmas are too hot to contain with solid materials. Fortunately, a group of successful plasma confinement devices called tokamaks offer a unique opportunity to study fusion reactions within the context of plasma dynamics. My dissertation topic comprises designing a new instrument, or diagnostic, called the Charged Fusion Product Diagnostic (CFPD) to study plasma behavior and instabilities in a tokamak through detecting the products of these nuclear fusion reactions.

Tokamaks use magnetic coils and high currents to create toroidal and poloidal (see Figure 1) magnetic fields to confine a plasma within the vessel; this prevents the plasma from touching its walls. While conventional tokamaks confine a plasma into a torus shape, spherical tokamaks confine a plasma into a radially compressed torus shape (see Figure 2). To bring the plasma to temperatures of the order of 10^8 K to facilitate nuclear fusion reactions, the tokamak incorporates several heating methods, notably the Neutral Beam Injection (NBI) of energetic ions into the plasma.[5, p. 476] Once the plasma reaches a stable equilibrium, toroidal surfaces of constant plasma current, temperature, pressure, and magnetic flux form inside of the plasma. Magnetohydrodynamic (MHD) instabilities in the plasma, however, can compromise equilibrium and displace these toroidal surfaces, negatively affecting a plasma's ability to facilitate nuclear fusion reactions.

The CFPD focuses on deuterium-deuterium nuclear fusion reactions during the NBI. One proton and one neutron composes the nucleus of deuterium, an abundant stable isotope of hydrogen. Fusion reactions between deuterons, deuterium that becomes ionized by losing an electron, take place within the plasma. When two deuterons fuse, they can create a proton and a triton (unstable isotope of hydrogen) or a neutron and an isotope of helium. Charged products from this nuclear fusion reaction follow trajectories dependent upon the magnetic field configuration in the plasma. The CFPD's main interest lies in the protons with energies of 3MeV and tritons with energies of 1MeV as they have a gyroradius of the order of the radius of the plasma itself; this allows them to leave the plasma very quickly and are therefore not confined. As they leave the plasma, they can hit the vessel wall or a well-placed detector. Since diagnostics cannot withstand the extreme conditions inside of the plasma, they must study plasma properties from a distance such as the tokamak vessel wall.

1.2 Research Objective

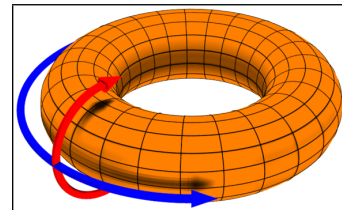

Figure 1: The red line indicates the poloidal direction and the blue line indicates the toroidal direction.[12]

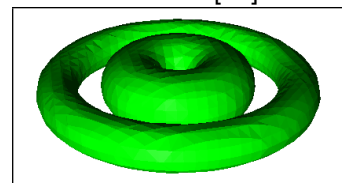

Figure 2: A radially compressed spherically shaped toroidal plasma inside of a conventional toroidal plasma for a visual comparison.

Charged fusion product studies have focused on evaluating plasma heating method performance through detecting particle loss in specific regions of the plasma.[7] During preliminary attempts to create a fast ion emission profile in the Axially Symmetric Divertor EXperiment, Bosch noted that the original diagnostic design prevented discussion regarding where the protons and tritons were produced in the plasma.[3] Strachan's experiment took advantage of proton motion in the magnetic field to detect the protons as they drifted toward the vessel walls; these measurements, however, had a low time and position resolution.[9] Though Zweben was able to clearly detect signals from alpha particles, they had broad pulse widths resulting in "a lack of intrinsic energy resolution;" this study has not been done for a spherical tokamak.[10] Additionally, while increased plasma densities in the National Spherical Torus Experiment Upgrade (NSTX-U) will result in smaller signals for its current primary diagnostics measuring the neutral beam ion density profile, increased plasma densities and reaction rates will increase the time resolution of the CFPD. [8][6]

My research focus is to find out where and at what rates in the plasma the previously discussed particles are created, the emission profile. A prototype diagnostic will be designed, constructed, assembled, and installed in the Mega Amp Spherical Tokamak (MAST) in the Culham Centre for Fusion Energy (CCFE) in the United Kingdom for data collection. Subsequent data analysis will be used to reconstruct the time-dependent charged fusion product profile from deuterium-deuterium reactions in the plasma (see Table 1). MAST neutron count rates measured by the Fission Chamber and Neutron Camera will act as an ideal validation of the CFPD, as it measures the same profile through a different technique.[4] The emission profile will allow studies of plasma instabilities (such as toroidal Alfvén eigenmodes and fishbones) and neutral beam ion density profile effects on plasma stability. Plasma instability studies become vital to reduce hindrances on plasma performance so as not to impede efficient fusion energy production. The CFPD provides the foundation for future research in spherical tokamaks, especially as these devices upgrade to higher density plasmas.

TERM	MAJOR GOALS
Summer 2012	Diagnostic design/ assembly/ testing
Fall 2012	Diagnostic design/ assembly/ testing, apply for 2013 fellowship
Spring 2013	Initial testing and Electrical Design Review at MAST
Summer 2013	Diagnostic installation and data collection at MAST
Fall 2013	Data analysis, dissertation, apply for 2014 fellowship
Spring	Data analysis, dissertation
Summer 2014	Data analysis, dissertation, write paper for publication
Fall 2014	Dissertation defense and submit paper for publication

Table 1: Timeline to degree completion.

2 Experimental Design

2.1 Simulations

Previous studies have made use of Monte Carlo simulations, computer codes, to calculate proton trajectories, also called orbits or sight lines, backwards in time from the detector into the plasma to the point of its origin.[3][11] We use a modified version of the Lorentz orbit code, which has been updated, for calculating particle orbits along with their emission profile or emissivity in the plasma; this makes use of MAST's equilibrium magnetic field configuration and magnetic flux data (see Figure 3). A simple power law function utilizing the geometry and properties of the plasma's toroidal surfaces is used to calculate the expected emission profile and the detector efficiency (how many particles it detects along a sight lines compared to the total

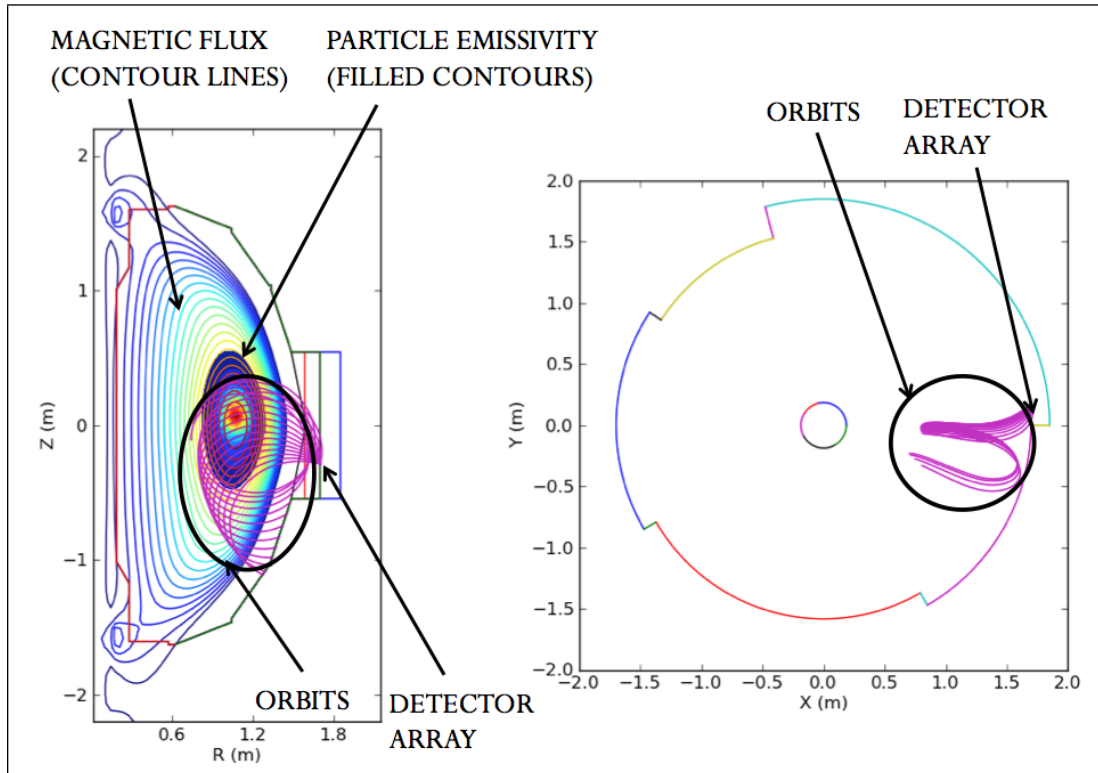

Figure 3: Software has been developed to visualize particle orbits within the plasma as they hit an array of detectors near the tokamak vessel wall. (a) Poloidal view of proton orbit/ trajectory sight lines associated with a detector array. (b) Mid-plane toroidal view of particle orbit sight lines in plasma.

number of particles created). Different orientations are simulated so that the actual physical orientation of the detectors with respect to the tokamak vessel wall, plasma boundaries, and magnetic fields, can be chosen to sample the central hottest region of the plasma.

2.2 Mechanical Design

A non-magnetic stainless steel module designed to house silicon surface barrier detectors will attach to an already existing probe arm on MAST, which will move the diagnostic into the tokamak vessel near the edge of the plasma for data collection. An outer ceramic cover will shield sensitive equipment from the plasma temperature and accompanying electromagnetic fields inside the vessel. Thin foils will cover the surface of the detector's active area to filter out signals from soft x-rays and light emitted by the plasma. A dielectric plastic will insulate the detectors from the steel housing unit to avoid electrical noise drowning out the small detector signals.

All pieces, aside from the ceramic shield, will be manufactured by the FIU Physics Department Machine Shop. I have designed and created machine drawings for all pieces to be manufactured, with the exception of a few pieces MAST requires us to replicate. The mechanical design, see Figure 4, also takes into account thermal expansion for different materials; all materials have to be approved for use in Ultra High Vacuum (UHV), up to 10^{-10} Torr. This design concept has been approved in a MAST Design Review.

2.3 Electronics and Data Acquisition (DAQ) Design

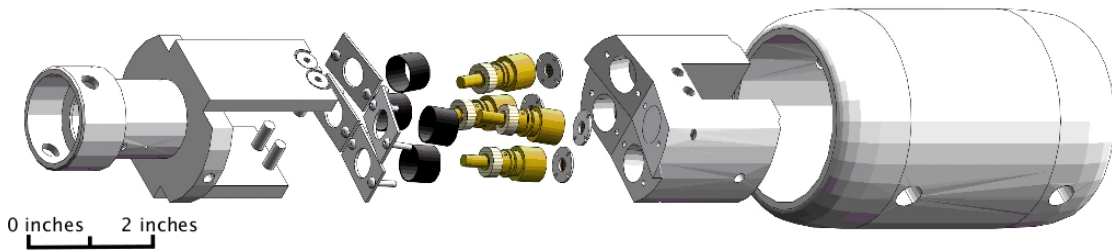

Figure 4: Diagnostic Computer Aided Design (CAD) drawing.

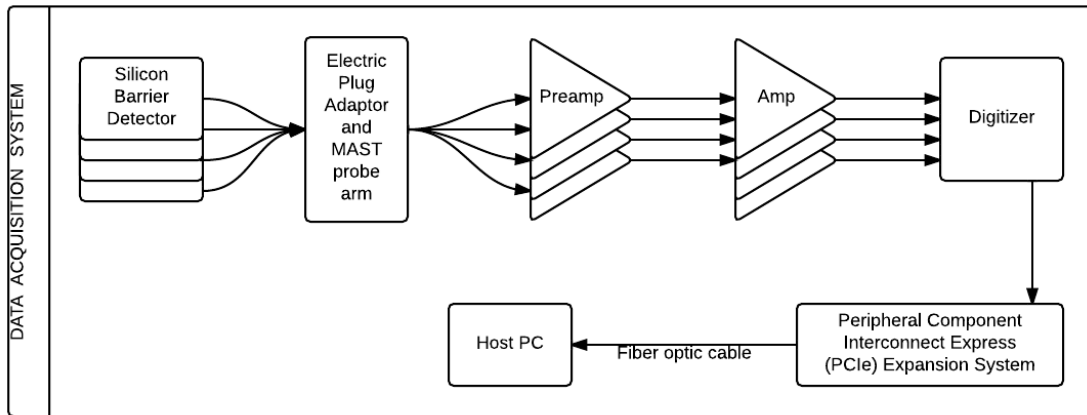

Figure 5: Data acquisition schematic.

UHV coaxial cables will connect the four detectors (to detect proton and triton signals) to the end of the probe arm. On the air-side of the vessel at the beginning of the probe arm, preamplifiers will connect to timing filter amplifiers leading to input channels of a high speed 60 MHz digitizer, which is installed on a PCI expansion box connected to a rack mount computer through a fiber optic cable. Data from the digitizer are transferred to the computer and stored as Hierarchical Data Format (HDF) files (see Figure 5). Using LabVIEW software installed on the computer, I will control the data collection parameters such as the digitizer rate and collection time through custom written and configurable programs for data acquisition. An HDF file size of 23MB per channel for 0.5s of digitized data, at a rate of 60 MHz, will be used to estimate data storage for MAST experiments. Our DAQ has been created to collect data for particle rates up to a few MHz.[2]

3 Data Collection and Data Analysis

Data collection in MAST, located at the CCFE, will take place in May of 2013 for several weeks. I am currently in communication with MAST colleagues regarding data collection preparations, including a formal collaborative research proposal for the MAST 2013 campaign. I will ship all major components of the CFPD to CCFE and install them in MAST. Test runs and an Electrical Design Review of the diagnostic in the Spring of 2013 will provide an opportunity to assess noise levels and any induced electromagnetic interference normal machine operations might create.

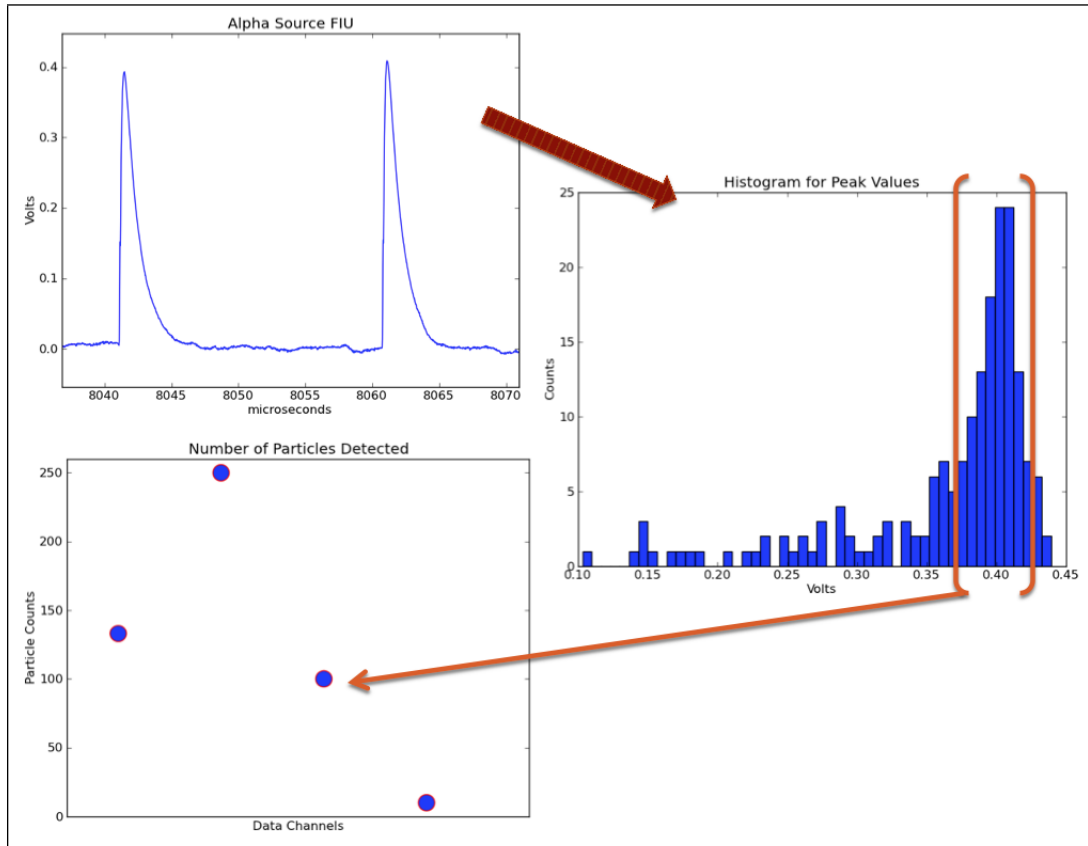

Figure 6: An example of pulses from raw data, which once analyzed will be binned and integrated to reveal particle count rates for comparison to MAST particle yield rates.

Using equilibrium condition magnetic field configurations for MAST, our simulation software will be used to determine the trajectories along which emitted charged particles (particularly protons) are detected. The actual data, voltage values recorded in HDF files, will be calibrated to reveal pulses created by protons and tritons. Calibration will take into account plasma current data, plasma instabilities, plasma temperature, and signals from operating machinery. Data for these will be available from the CCFE. Pulses will be binned to find traces of protons and tritons. The binned data can then be integrated, along time intervals, to be counted and compared to MAST particle yield rates (see Figure 6).[4] Analysis will yield the proton and triton rates detected for comparison with simulated results. Simple models for the power law emission profile function will be fitted to this first set of data.

The proton emission profile will be of particular interest to validating theoretical models of MHD instabilities which can deteriorate plasma performance. Successful data analysis and contributions towards plasma efficiency will motivate the design and implementation of a future sixteen channel CFPD for the NSTX-U.

References

- [1] J. A. Bittencourt, *FUNDAMENTALS OF PLASMA PHYSICS*. Springer Science + Business Media, LLC, 3rd Edition, 2004.
- [2] W. U. Boeglin, R. Valenzuela Perez, D. S. Darrow, *Rev. Sci. Instrum.* **81** (2010) 10D301
- [3] Hans-Stephan Bosch *Rev. Sci. Instrum.* **61**, 1699 (1990)
- [4] M. Cecconello, et. al., *Rev. Sci. Instrum.* **81**, 10D315 (2010)
- [5] Jeffrey Freidberg, *Plasma Physics and Fusion Energy*. Cambridge University Press, 2007.
- [6] D. Liu, et. al., *Rev. Sci. Instrum.* **77** 10F113 (2006)
- [7] Daniel H. Lo, R jean L. Boivin, and Richard D. Petrasso *Rev. Sci. Instrum.* **66**, 345 (1995)
- [8] M. Podest , et. al., *Rev. Sci. Instrum.* **79**, 10E521 (2008)
- [9] J. D. Strachan *Rev. Sci. Instrum.* **57**, 1771 (1986)
- [10] S. J. Zweben *Rev. Sci. Instrum.* **57**, 1774 (1986)
- [11] S. J., Zweben, et al., *Nucl. Fusion* **35**, 893 (1995)
- [12] An image depicting the poloidal (red, called theta) direction and the toroidal (blue, called phi) directions. Notably absent is the radial coordinate which starts from the center of the tube and points out. 13 September 2006. Made in POV-Ray by Dave Burke. PNG File.